

User Manual

Patara-IR TEM₀₀ Laser
PA-020-QTIP

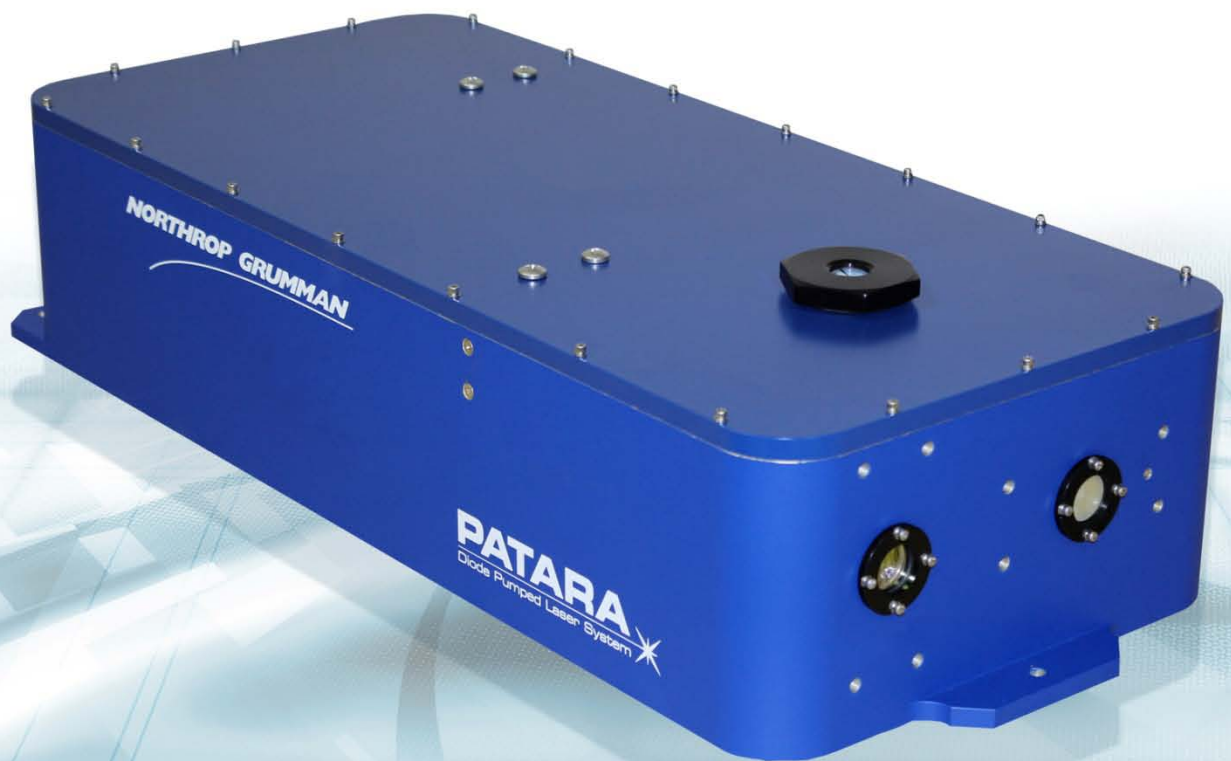

February 2014
CEO-UMAN-0045
Rev B

NORTHROP GRUMMAN

Worldwide Technical Support and Product Information

<http://www.northropgrumman.com/BusinessVentures/CEO/Pages/Service.aspx>

<http://www.ngceoservice.com/> (Knowledge Center)

Hours: 8:00 a.m. to 5:00 p.m., Central time*

Technical Support: (636) 916-4900 (follow prompts for department directory)

Email: ngceoservice@ngc.com

Cutting Edge Optronics Headquarters

20 Point West Blvd. St. Charles, MO 63301 USA

Sales Support: (636) 916-4900 (follow prompts for department directory)

*After office hours, please leave a voice mail message. Outside North America, contact a Cutting Edge Optronics sales office or distributor; see the Cutting Edge Optronics website for a list of offices.

© 2014 Cutting Edge Optronics, a strategic business unit of Northrop Grumman Systems Corporation. All rights reserved.

Important Information

Warranty Summary

Northrop Grumman Cutting Edge Optronics (NG CEO) warrants that the products that it manufactures and sells will be free from defects in materials and workmanship for a period of one year from the date of shipment from an NG CEO distributor. If a product proves defective within the respective period, NG CEO will provide repair or replacement as described in the complete warranty statement.

To arrange for service or obtain a copy of the complete warranty statement, please contact your nearest NG CEO sales and service office.

EXCEPT AS PROVIDED IN THIS SUMMARY OR THE APPLICABLE WARRANTY STATEMENT, NG CEO MAKES NO WARRANTY OF ANY KIND, EXPRESS OR IMPLIED, INCLUDING WITHOUT LIMITATION THE IMPLIED WARRANTIES OF MERCHANTABILITY AND FITNESS FOR A PARTICULAR PURPOSE. IN NO EVENT SHALL NG CEO BE LIABLE FOR INDIRECT, SPECIAL, OR CONSEQUENTIAL DAMAGES.

Copyright

Under the copyright laws, this publication may not be reproduced or transmitted in any form, electronic or mechanical, including photocopying, recording, storing in an information retrieval system, or translating, in whole or in part, without the prior written consent of NG CEO.

Trademarks

Patara, eDrive, eDrive Nitro, and Timing Engine are registered trademarks of Northrop Grumman Corporation.

Patents

Northrop Grumman Corporation products are covered by U.S. and foreign patents, issued and pending. Information in this publication supersedes that in all previously published material. Specifications and price change privileges reserved.

Export

This laser product is regulated by the Export Administration Regulations (EAR) of the USA. It may not be export/re-export without the prior written approval of the Bureau of Industry and Security, U.S. Department of Commerce.

Safety Information

Product End-of-Life Handling



NG CEO is committed to protecting the environment. In accordance with the Waste Electrical and Electronic Equipment directive (WEEE) and Restriction of Hazardous Substances in the European Union (RoHS EU) directives, NG CEO accepts the return of our products for disposal. When you are ready to reclaim the instrument, you must properly transfer it according to local regulations concerning WEEE equipment. Contact NG CEO or your local distributor for shipping instructions. Please package the products as directed for a return for repair.

ROC ROHS Declaration

In accordance with the Clause 6.2 of Marking for Control of Pollution Caused by Electronic Information Products (SJ/T11364:2006) for Measures for the Administration on Pollution Control of Electronic Information Products No. 39, Order of the Ministry of Information Industry of the Peoples Republic of China, NG CEO includes the following translation about our laser modules.

中华人民共和国，电子讯息产品管理办法：自我声明							
生产商		Northrop Grumman Cutting Edge Optonics					
生产商地址		20 Pointe West Blvd St. Charles, MO 63301 USA					
产品名称 / 编号		Mirus Series Laser Systems Models: MI-xxx-xxxx-xxxx and AMI-xxx-xxxx-xxxx					
有毒有害物质或元素标识表							
部件编号	部件名称	有毒有害物质或元素					
		铅 (Pb)	汞 (Hg)	镉 (Cd)	六价铬 (CrVI)	多溴联苯 (PBB)	多溴二苯醚 (PBDE)
第一组	外壳	○	○	○	○	○	○
第二组	电线/ 连接插头	X	○	X	X	X	X
第三组	安装组件	○	○	○	X	○	○
第四组	开关组件	○	○	○	X	X	X
第五组	电路板/ 开关组件	X	○	○	○	X	X
第六组	阵列前端次模组	○	○	○	○	○	○
第七组	接触板	X	○	○	○	X	X
第八组	热交换组件	○	○	○	○	○	○
第九组	16 进制硬件	○	○	X	○	○	○
第十组	焊锡	X	○	X	○	○	○
第十一组	电线/ 连接插头	X	○	○	○	X	X
第十二组	基部/ 端帽	X	○	○	X	○	○
第十三组	硬件/ 装配	○	○	○	X	○	○
第十四组	時計组件	X	○	○	X	X	X
第十五组	包装物料	○	○	○	○	○	○
O: 表示该有毒有害物质在该部件所有均质材料中的含量均在 SJ/T 11363-2006 规定的限量要求以下							
X: 表示该有毒有害物质至少在该部件的某一均质材料中的含量超出 SJ/T 11363-2006 规定的限量要求							

Conventions

The following conventions appear in this manual:



This icon denotes a caution or a warning, which advise you of precautions to take to avoid injury, data loss, or a system crash.

Initial Capped

The first letter in uppercase refers to menu options, e.g., **Phase Delay**, **Pulse Width**.

CAPS

Front-panel buttons, knobs, and connectors appear in all uppercase letters, e.g., **MENU**, **CURRENT**.



The ► symbol separates a sequence of button pushes, e.g., **MENU ► CHANNEL SETUP ► PULSE WIDTH** means that you push the **MENU** button, then push the **CHANNEL SETUP** soft key, and then push the **PULSE WIDTH** soft key.

italic

Italic text denotes references to other resources that may be helpful to you or to bring attention to important information.



This icon denotes a note, which alerts you to important information.



Power Switch Position Symbols
I = On O = Off

The following conventions may appear on the product:

DANGER

An injury hazard immediately accessible as you read the marking.

WARNING

A hazard not immediately accessible as you read the marking.

CAUTION

A hazard to property including the product.



ESD: Handle Appropriately



Laser Emission: Use caution.



Shock Hazard: Use caution.



Caution: Risk of danger. Refer to manual.

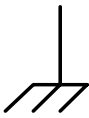

Chassis Ground

General Safety Summary

The Patara-IR TEM₀₀ Laser System emits laser radiation that can permanently damage eyes and skin, ignite fires, and vaporize materials. *Chapter 2: Laser Safety* contains information and guidance about these hazards. To minimize the risk of injury or expensive repairs, carefully follow these instructions.

Do not attempt to operate the laser system before carefully reading this complete operation manual. If you have any questions on the product that have not been discussed sufficiently in this manual, contact the manufacturer for complete instructions. **Failure to heed this warning may result in the destruction or serious damage to the device, and will void the product warranty.**

The *Service* and *Troubleshooting* sections are intended to help guide you to the source of problems. Do not attempt repairs while the unit is under warranty; instead, report all problems to NG CEO for warranty repair.

Use the form in *Appendix A: Customer Service* to describe issues with the laser. We also suggest that you record information about the laser such as power, settings, time and date.

About This Manual

This manual describes the installation, operation, and service of the Patara-IR TEM₀₀ Laser System with the eDrive Nitro Laser Controller. The manual consists of the following chapters:

- *Chapter 1: Introduction* provides a theory of laser operation and a description of the Patara-IR TEM₀₀ laser.
- *Chapter 2: Laser Safety* describes proper safety procedures you should understand before operating the Patara-IR TEM₀₀ laser.
- *Chapter 3: System Details* provides information about components of a laser system and proper environmental conditions for operation.
- *Chapter 4: Installation and Operation* discusses how to unpack, setup, and powering on your system for the first time.
- *Chapter 5: Maintenance* provides information on proper maintenance of your laser system.
- *Chapter 6: Service* provides resources to help fix problems with the Patara-IR TEM₀₀ laser.
- *Chapter 7: Troubleshooting* provides possible solutions to the most commonly reported issues with the Patara-IR TEM₀₀ laser.
- *Appendix A: Customer Service* provides information to expedite any service request before contacting NG CEO.
- *Appendix B: System International Units* identifies commonly used units of measurement found in this manual.
- *Appendix C: Acronyms* provides a list of commonly used abbreviations and their descriptions used throughout this manual.

Table of Contents

Chapter 1: Introduction	1
Theory of Operation	2
System Description	3
Specifications	4
Chapter 2: Laser Safety	7
Safety Overview	8
Precautions for Safe Operation	8
Center for Devices and Radiological Health Compliance	9
Chapter 3: System Details	12
Patara-IR TEM ₀₀ Laser	13
Closed Loop Chiller	15
eDrive Nitro	20
Chapter 4: Installation and Operation	22
Laser System Components	23
Unpacking the Laser System	23
Laser Head Setup	25
eDrive Setup	26
Chiller Setup	27
Connecting the Chiller	29
PolyScience 6000 Series Power-Up Procedure	34
First Time Laser Power-Up Procedure	35
Daily Operation	37
Adjusting the Laser System	39

External Triggering and FPS	40
Chapter 5: Maintenance	41
Prepare for Shipment	42
Purge Housing	42
Replace Desiccant Cartridge	43
Clean and Maintain Chiller	45
Check Hold Off	47
Extend Lifetime of Laser Diodes	47
Optimize Laser Performance	47
Chapter 6: Service	52
Contacting Customer Service	53
Laser Module Replacement	53
Return the Instrument for Repair	53
Chapter 7: Troubleshooting	54
Initial Checklist	55
Laser Output Power	55
eDrive Operation	57
Appendix A: Customer Service	59
Questions	60
Appendix B: System International Units	62
Appendix C: Acronyms	63
Index	65

List of Figures and Tables

Figure 1-1 Typical System Block Diagram	3
Table 1-1. Typical Performance of a Standard Patara-IR TEM ₀₀ Laser	4
Table 1-2. Other Specifications Table	5
Figure 2-1 Example of Radiation Control Drawing	10
Figure 2-2 Warning Labels	11
Figure 3-1 Patara-IR TEM ₀₀ Front View	13
Figure 3-2 Patara-IR TEM ₀₀ Rear View	13
Figure 3-3 Patara-IR TEM ₀₀ Top View	14
Table 3-1 Heat Capacity and Minimum Flow Rate	15
Table 3-2 Cooling System Requirements	16
Table 3-3 Avoid with Chillers	16
Figure 3-4 Constant Dew Point Lines for Ambient Temperature and Relative Humidity	19
Table 3-4. Table of Air Condensation Temperature at Given Ambient Air Temperature (Celsius) and Relative Humidity (percent)	20
Figure 3-5. eDrive Nitro Control Panel	21
Figure 4-1 Components for the Patara-IR TEM ₀₀ Laser	23
Figure 4-2. Basic setup for the laser power test	25
Table 4-1. Recommended Fuse Ratings	26
Figure 4-3. Coolant Hoses and Filter Connections	29
Figure 4-4. Chiller Assembled with Coolant Hoses and Filter	30
Figure 4-5 Connectors on the rear panel of the Patara-IR TEM ₀₀ laser	30
Figure 4-6. Plumbing Connection	31
Figure 4-7. Signal Connection	31

Figure 4-8. Diode Power Connection	31
Figure 4-9. RF Connection	32
Figure 4-10 Laser Signal Cable	32
Figure 4-11 Diode Power Cable	32
Figure 4-12 RF Signal Cables	33
Figure 4-13 Chiller Interlock Connector	33
Figure 4-14 White Interlock Connectors	33
Figure 4-15 BNC Interlock Connection	34
Table 4-2 eDrive settings	36
Figure 5-1 40 Gram Desiccant Cartridge Top	44
Figure 5-2 40 Gram Desiccant Cartridge Bottom	44
Figure 5-3 50 Gram Refill and Refill Tool	45
Figure 5-4 Example of Laser Performance Dependence on the Operating Current	49
Figure 5-5 Accessible Holes for HR and OC Mirror Adjustment	50

Chapter 1: Introduction

This introduction provides the following information:

- Theory of operation
- System description
- Specifications

Theory of Operation

Patara Laser PA-020-QTIP is a Q-switched fundamental transverse mode infrared laser. The output consists of pulses of light at 1064 nm wavelength and less than 100 nanosecond pulse duration at repetition frequencies of 10 kHz. It is a TEM₀₀ laser and therefore has very high brightness. The CW pumped Nd:YAG rod module in the oscillator is optically excited using arrays of laser diode bars operating at wavelengths in the neighborhood of 806 nm.

A laser oscillator consists of an optical amplifier in an optical cavity which serves to form a laser optical mode which can oscillate when the gain of the amplifier is sufficient to overcome the losses in the optical cavity. One such loss is the amount which is allowed to escape the oscillator cavity through one of its mirrors and constitutes its useful output.

The Nd:YAG laser amplifier is capable of storing a considerable amount of energy due to the long upper state lifetime of the Nd ion. If some kind of device is used to prevent the buildup of optical power in the oscillator cavity by introduction of loss greater than the available gain, energy will accumulate in the gain medium. If this same device suddenly removes this loss, the laser power will increase exponentially with each round trip of the oscillator cavity until much of the stored energy is exhausted and the gain once again falls below the loss. The fact that the time for light to transit the laser cavity is only a few nanoseconds results in this stored energy being released in a very short duration pulse. Such a device is called a Q-switch and they are available in two major types, acousto-optic and electro-optic. The Patara laser uses an acousto-optic Q-switch to form its pulses. The high peak power is achieved in this manner.

The laser beam which can circulate inside the oscillator cavity is determined by a process of self-consistency where the beam characteristics at any given location in the cavity are repeated after the beam completes a round trip back to that location. Oscillator beams are composed of transverse modes of simple structure related to a fundamental Gaussian intensity profile mode which is of the smallest lateral extent and divergence in the set. Somewhere in the oscillator path is an aperture which forms the limit to the laser beam's transverse spatial extent. It is advantageous for achieving the ultimate power and efficiency from a given laser system for this aperture to coincide with the aperture of the amplifier medium, so that the oscillating beam fills the gain medium to the maximum extent. If the diameter of the fundamental mode is much smaller than the limiting aperture, higher order modes will oscillate and laser beam quality will degrade because these modes have not only a larger transverse extent, but also have higher divergence than the fundamental mode. Beam quality is therefore related to the product of the diameter of the beam and its angular divergence as it propagates into the far distance, and this product is conserved with propagation and transformation by optical elements such as lenses and mirrors. Beam quality is also a measure of how small of a spot a beam can be reduced by simple focusing: higher quality beams give focal spots of smaller diameter and higher intensity. The subject of laser cavity design for fundamental mode operation is too involved to pursue here, but it involves the selection of cavity length and the characteristics of the pumped amplifier medium's diameter and focal power. It is important to recognize that once the design parameters are selected for optimum fundamental mode operation, they cannot be altered without perturbing the fundamental

mode size in the amplifier which may lead to unacceptable changes in performance. This is particularly important to the intensity of amplifier excitation (pump power, or drive current) since this also determines its focal power. Consequently, the amplifier drive current must be kept at all times within a close tolerance of the design point.

Suppose, however, that it is necessary to turn the laser output power down from its maximum design value. From the reasoning above, one cannot just turn the power down to the amplifier thereby reducing its gain without unacceptable alterations in the beam characteristics because this is invariably accompanied by a change in its focal power. While it is always possible to attenuate the beam externally to the laser oscillator cavity, this is undesirable since it involves additional optical elements and expense. A corresponding reduction of power, however, is possible if we could turn up the loss of the optical cavity while maintaining the gain at a constant level. The Patara-IR TEM₀₀ laser achieves power reduction using the latter method. The additional functionality of accepting and executing power level commands is built into the accompanying eDrive electronic system.

System Description

The Patara-IR TEM₀₀ laser consists of three interconnected subsystems. The optics subsystem contains the laser oscillator, the eDrive electronic subsystem provides power and control for the laser transmitter, and the chiller provides thermal control. The user must supply prime power and cooling to the optics subsystem. The interface relationships among these subsystems are illustrated in Figure 1-1.

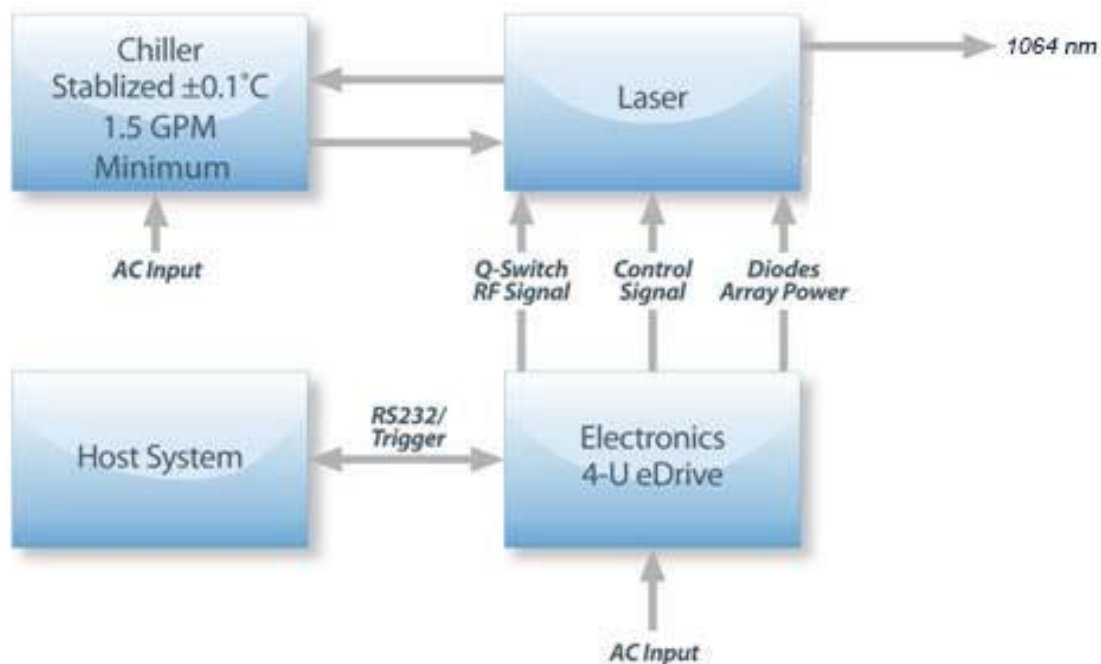

Figure 1-1 Typical System Block Diagram

Specifications

Table 1-1. Typical Performance of a Standard Patara-IR TEM₀₀ Laser

Parameter	Units
Laser Model	PA-020-QTIP
Laser Type	DPSS Nd:YAG
Wavelength	1064 nm
Repetition Rate	5 to 30 kHz
Output Power @ 10 kHz	20 W
Spatial Mode	TEM ₀₀
Beam Diameter @ 10 kHz	0.9 mm
Beam Quality (M ₂) @ 10 kHz	≤ 1.3
Beam Divergence (FWHM) @ 10 kHz	2.5 mrad
Pulse Width (FWHM) @ 10 kHz	< 100 ns
Pulse-to-Pulse Stability @ 10 kHz	< 1.5 % rms
Output Stability (Over 8 hours) @ 10 kHz	< 3 % rms

Table 1-2. Other Specifications Table

Parameter	Performance
Electrical Inputs	eDrive Auto-ranging: 85-264 VAC @ 47-63 Hz Drawing 7A
Cooling	Closed Loop Re-circulating Chiller ¹
Coolant	Distilled Water with 10% Optishield Plus ²
Operating Temperature	18-30 °C
Laser head size	26" L x 6.1" H x 11.5" W
eDrive Nitro Size	7" H x 19" W x 17.7" D

¹ Chiller must be able to circulate a minimum of 1.5 GPM of coolant at approximately 60 psi. See the ATP test report data summary sheet supplied with the laser for the exact flow rate required.

² The laser can be cooled with distilled water as long as a corrosion inhibitor and algicide are added. NG CEO recommends Optishield Plus.

Optics Subsystem

The optical subsystem consists of an optical assembly on a NG CEO industrial laser optics bench. The optical assembly is kinematically mounted to the housing.

Electronic Subsystem

The electronic subsystem consists of a 4U sized eDrive (see the eDrive User Manual for details). Refer to *Chapter 4: Installation and Operation* to setup and operate the eDrive with the Patara-IR TEM₀₀ laser. Contact NG CEO technical service if you need assistance.

Operation at reduced power requires that two settings be adjusted in the eDrive: the **Q-switch Power**, and the drive current level **Iset**. Your laser shipment includes the final ATP test report data summary that provides the values necessary to achieve the full power conditions.

Thermal Control Subsystem

Thermal control and heat removal from the Laser Transmitter is accomplished by a chiller provided by CEO or the user. The laser has an integral flow switch which will interrupt drive current to the amplifier module and power to the Q-switch should the flow rate fall below 1 GPM (3.8 LPM). Flow direction is labeled on the laser optics housing below the coupler ports. Please observe the flow direction at all times.

The thermal control system must be capable of maintaining the temperature set point to $\pm 0.1^\circ\text{C}$ with a flow rate of 1.5 GPM (5.7 LPM). This will require a pressure of approximately 50 psi at the input to the laser housing in order to achieve the flow rate. Pressures at the chiller may be several psi higher if additional filtering, flow metering, fittings, and long runs of coolant tubing are used.

Coolant used in the system must be compatible with the materials used in the internal coolant lines of the laser. Tap or de-ionized water must be avoided because of corrosion and mineral deposits. NG CEO can supply an approved coolant for this application.

Chapter 2: Laser Safety

Please read this chapter carefully before installing or operating your laser. An NG CEO trained service engineer should perform all service and repair operations. If you plan to service your laser, please follow the procedures in *Chapter 5: Maintenance*.

Sections included in this chapter include:

- Safety Overview
- Precautions for Safe Operation
- CDRH Compliance

Safety Overview

Safe operation of any laser should be reviewed prior to any new installation of the Patara-IR TEM₀₀ laser.



CAUTION. The Patara-IR TEM₀₀ laser is a Class IV, high power laser whose beam is, by definition, a safety hazard. Avoid eye or skin exposure to direct or scattered laser radiation. Avoid direct viewing of the beam or its specular reflection.

Follow the instructions contained in this manual for proper installation and safe operation of your laser. We recommend the use of protective eyewear at all times (the type of eyewear depends on the energy and wavelength of the laser beam and operating conditions). Consult ANSI, ACGIH, or OSHA standards for guidance.



CAUTION. Use of controls, adjustments or performance of procedures other than those specified herein may result in hazardous radiation exposure.



WARNING. At all times during installation, operation, maintenance, or service of your laser, avoid exposure to laser or collateral radiation exceeding the accessible emission limits listed in "Performance Standards for Laser Products," U.S. Code of Federal Regulations, 21 CFR 1040.10(d).

Precautions for Safe Operation

- Avoid looking directly into the laser beam or at specular reflection, even with protective eye wear on.
- Wear laser safety eyewear that is optically dense at the wavelengths of operation (798-816 nm pump light, 1064 nm).
- Provide a controlled access area for laser operation and limit access to those trained in laser safety principles.
- Post warning signs in prominent locations near the laser operation area.
- Use safety interlocks on all entryways. All NG CEO system control electronics are supplied with interlock inputs that can be used to preclude operation with an open safety door.
- Enclose beam paths wherever possible.
- Set up experiments so the laser beam is below eye level.
- Work in an area that is well lighted to avoid dilation of pupils.
- Set up a target for the beam.
- Set up shields to prevent reflected beams from escaping the laser operation area.

- View an infrared laser beam with a protected image converter at an oblique angle reflecting from a diffuse surface.
- Ensure that all electrical connections are made in a safe manner.
- Position equipment so that electrical connections are shielded from accidental touch.
- Do not smoke, eat, or drink in laser areas.
- Avoid leaving an operating laser unattended.

Center for Devices and Radiological Health Compliance

This laser product complies with Title 21 of the U.S. Code of Federal Regulations, Chapter 1, Subchapter J, Part 1040.10 and 1040.11, as applicable. To maintain compliance with these regulations, once a year or whenever the product has been subject to adverse environmental conditions (e.g. fire, flood, mechanical shock, spilled solvent), verify that the radiation controls such as shutter, laser on light, and audible warning are functioning properly. All warning labels should remain fully attached. (see Figure 2-1)

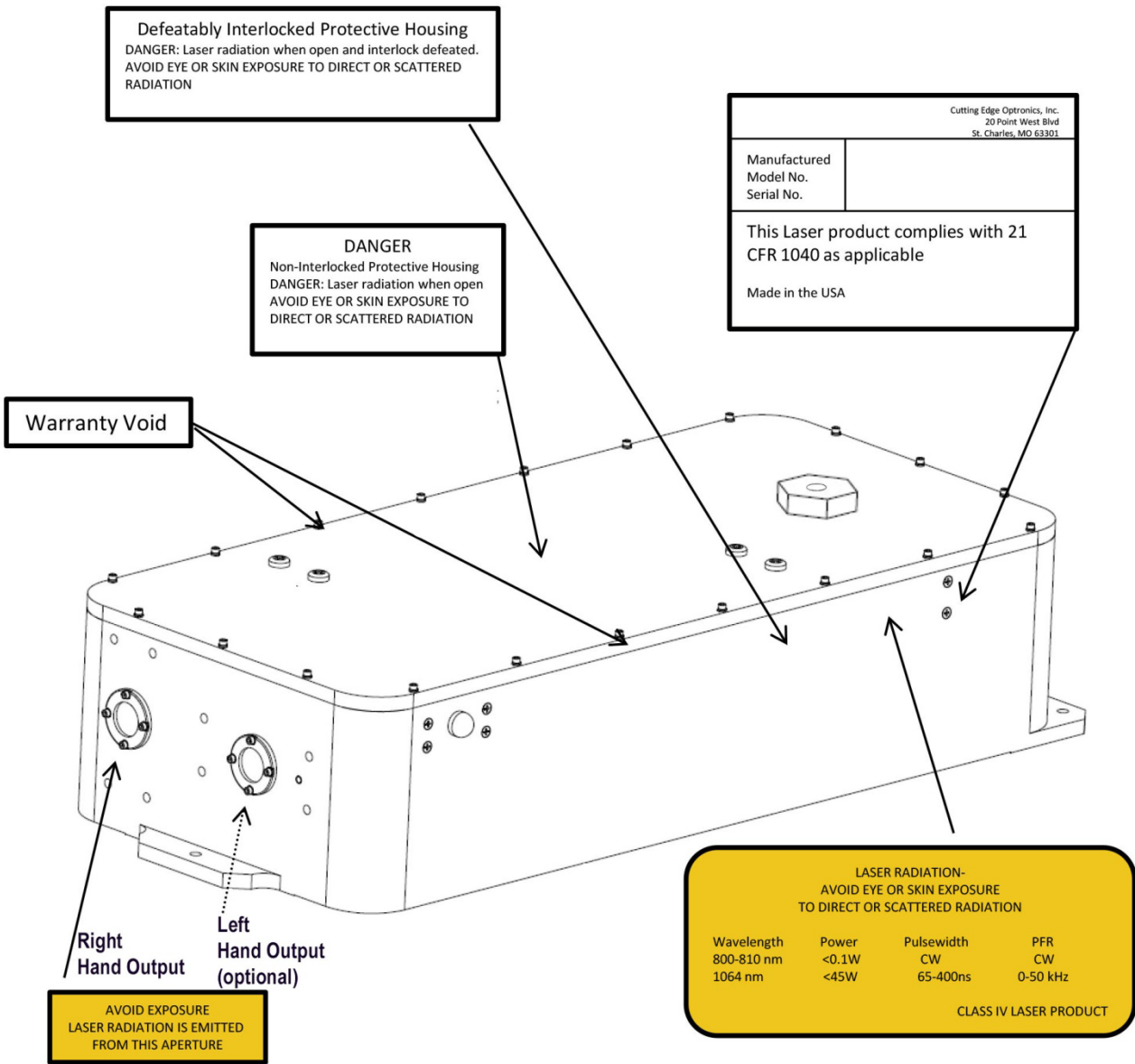

Figure 2-1 Example of Radiation Control Drawing

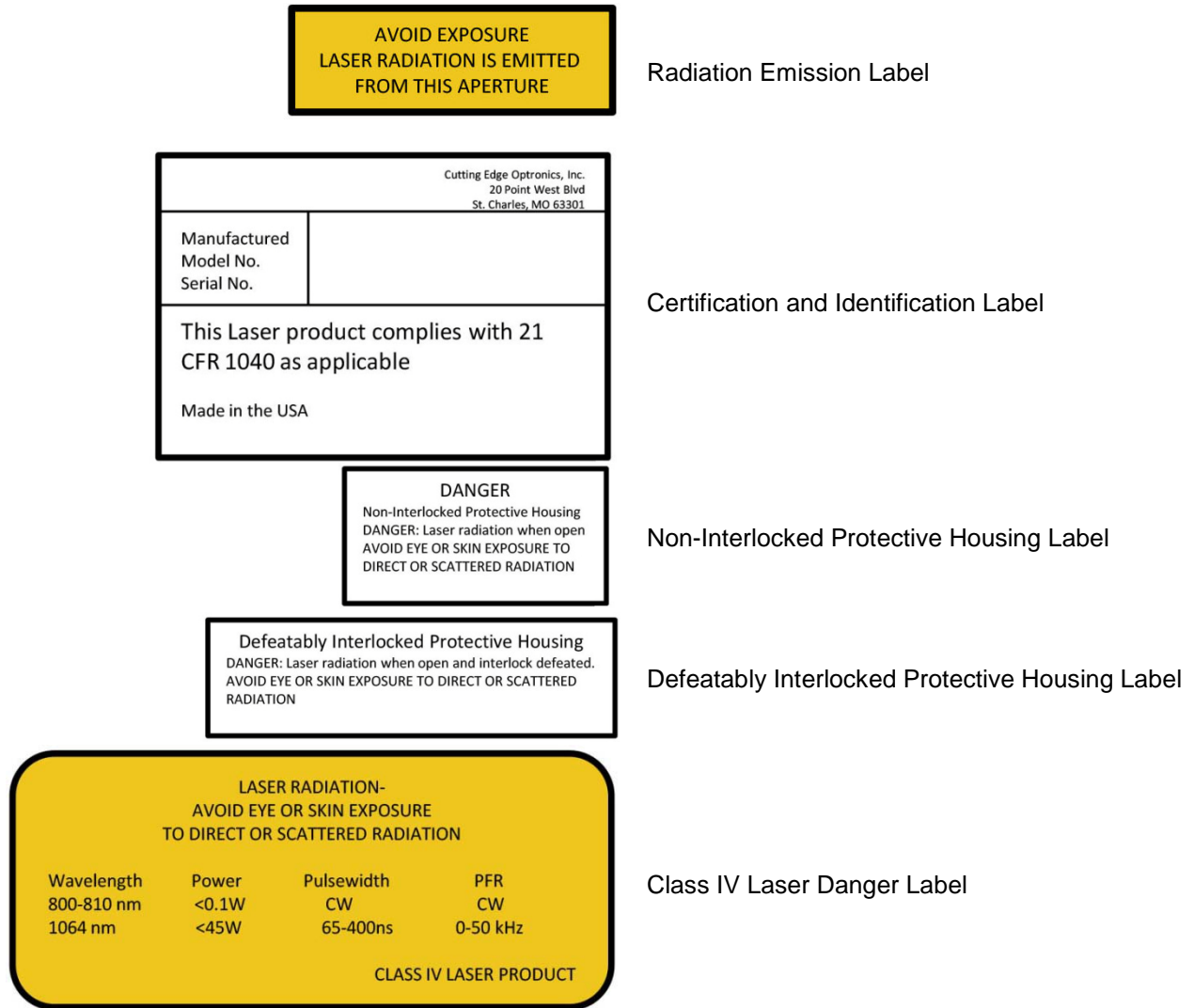

Figure 2-2 Warning Labels

Chapter 3: System Details

This chapter discusses the details of the Patara-IR TEM₀₀ laser:

- Patara-IR TEM₀₀ laser
- Closed Loop Chiller
- eDrive Nitro

Patara-IR TEM₀₀ Laser

The Patara-IR TEM₀₀ laser head measures 26 in L by 11 in W by 6.13 in H (not including the connectors at the rear of the laser). The side of the Patara-IR TEM₀₀ laser has a laser emission indicator. The laser can be configured for either right hand or left hand output. Please contact NG CEO for information regarding the location of the laser beam for your application.

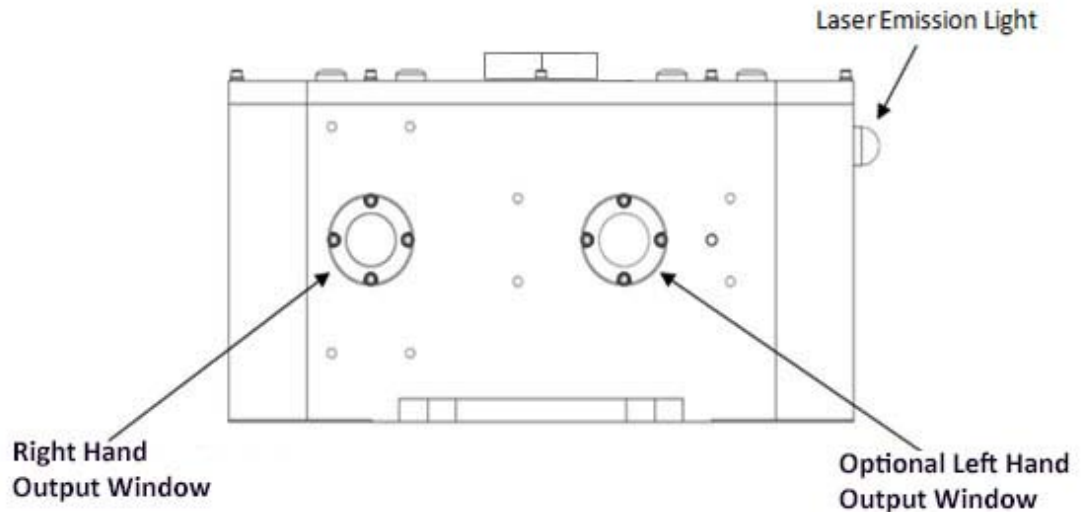

Figure 3-1 Patara-IR TEM₀₀ Front View

The rear panel of the Patara-IR TEM₀₀ laser has connectors for cables. These cables connect to the eDrive Nitro. The back panel also has ports for the coolant in and coolant out.

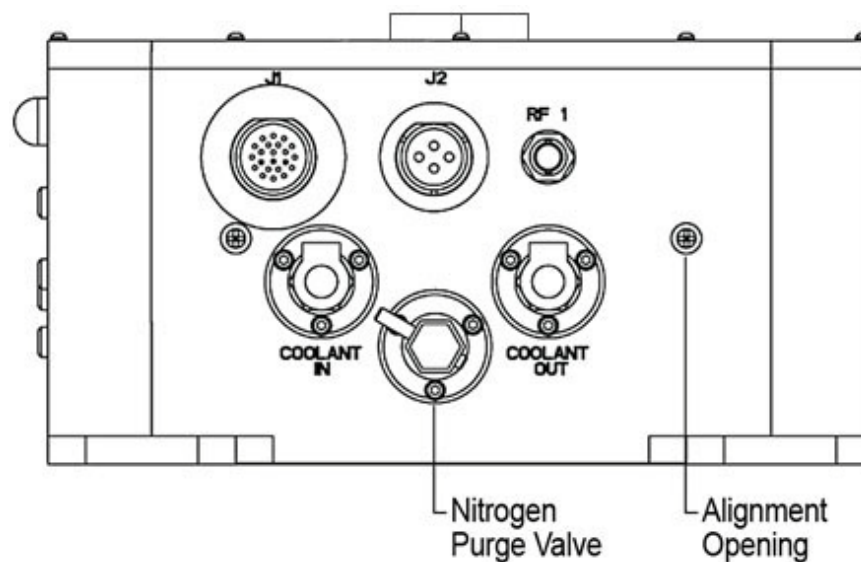

Figure 3-2 Patara-IR TEM₀₀ Rear View

Also located on the front and back panels are alignment openings. The openings are sealed by screws which prevent emission during normal operation. However, the service

technician can remove the screws and shine a HeNe laser through the opening to aid alignment.



WARNING. The screw filling the alignment hole is considered non-interlocked cover. If the screw is not replaced and the Patara-IR TEM₀₀ laser is running, the opening will function as an aperture. It can allow an output beam of up to 3 W at the same rep rate and pulse width as the main beam. This beam would be capable of causing eye or skin damage from direct exposure or specular reflection of the beam. Always replace the screw in the alignment hole.

Also to aid in aligning the laser, there are adjustment holes in the top cover of the laser housing to allow a technician to access the adjustment screw on the HR cavity mirror and OC cavity mirror. The following images show the position and use of each adjustment screw. The holes to access these adjustments are always open to air; there are no screws to block these holes, as they are not in the direct beam-path.



WARNING. The access holes should be always covered unless an alignment is being performed. Any dust invasion through these holes can cause damage to the mirrors and crystals inside the laser. All the holes on the laser enclosure should be sealed all times to prevent moisture penetration. Moisture in the enclosure can degrade the coatings on all optical components.

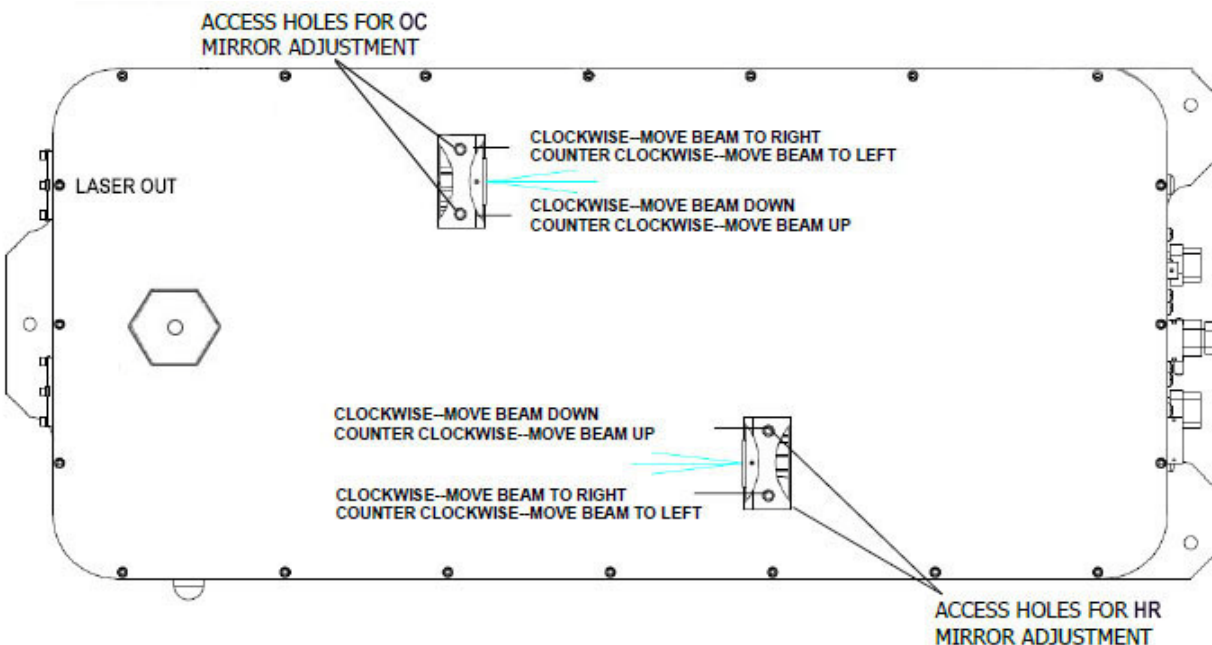

Figure 3-3 Patara-IR TEM₀₀ Top View

Closed Loop Chiller

The single most common cause of a laser returned for repair involves customer damage. More than one third of these damaged lasers result from cooling problems. Coolant problems almost always require the replacement of the diode arrays - the single most expensive component in NG CEO lasers. This section describes how to avoid damaging arrays.



WARNING. Do not operate laser without cooling. Inadequate heat dissipation will seriously damage the laser diodes and will void warranty.

Table 3-1 Heat Capacity and Minimum Flow Rate

Model	Heat Capacity ¹	Minimum Flow Rate
PA-020-QTIP	800 W	1.5 GPM (5.7 LPM)

¹ Heat capacity should be greater than the laser's power consumption.

Table 3-2 Cooling System Requirements

Chiller and Cooling System Requirements
Capable of recommended flow rate at 60 psi ¹
Optishield Plus mixed with distilled water (90% distilled water, 10% Optishield Plus) ²
Filter connected between chiller and inlet on laser ³
Chiller Heat Capacity > Laser Power Consumption
Flow sensor (installed internally on Patara lasers) ⁴
Replace coolant and filter monthly
<p>¹ It is acceptable if your chiller can achieve the required minimum flow rate through the laser with a lower pressure (typically around 50 psi). Do not operate the chiller above 70 psi.</p> <p>² Clean coolant keeps coolant lines from clogging. Untreated tap water may cause damage. Suitable coolants include: Optishield Plus from Opti Temp Inc, Traverse City, Mich., (231)946-2931. If Optishield Plus is not allowed due to local regulations, use Optishield.</p> <p>³ The filter should be capable of removing particles 5 µm or larger. The filter and coolant should be replaced each month or more frequently if the pH drops below 8 or the filter or coolant show any discoloration.</p> <p>⁴ When not using NG CEO drive electronics, verify that flow sensor interrupts current to diodes less than 1s after a low flow condition occurs.</p>

Table 3-3 Avoid with Chillers

Avoid with Chillers
De-ionized water ¹
Iron or aluminum parts in plumbing loop
Operation below air condensation temperature ²
<p>¹ The Patara-IR TEM₀₀ laser has exposed bare copper inside the coolant loop. For this reason, NG CEO does not recommend using untreated de-ionized (DI) water. If DI water is used as the coolant, it is important to maintain the water resistivity between 300 and 700 K ohms and to keep the water slightly basic (i.e., keep the water above 8.0 pH).</p> <p>² The Patara-IR TEM₀₀ laser is environmentally sealed, but not hermetically sealed. Atmospheric conditions near the exterior of the laser will mimic conditions inside laser head.</p>

Operating the Chiller



WARNING. Do not operate laser without cooling. Inadequate heat dissipation will seriously damage the laser diodes and will void warranty. If you notice coolant in the immediate vicinity of the laser, shut the laser system down immediately. Check to see if the coolant is coming from the laser head. If so, return the laser for repair. If not, repair the source of the leak and allow the unit to dry thoroughly before resuming operation.

The laser system has a coolant loop to prevent thermal damage to the laser diodes. The diodes should be kept at approximately 20 °C to 35 °C. See the ATP test report data summary included with your laser for optimum temperature and flow rate settings.

Operating the laser diodes for even a short period of time (even 1 second) without coolant will cause permanent damage. To help prevent this, all NG CEO drive electronics are equipped with a coolant interlock. This interlock interrupts drive current to the diodes when coolant flow rate drops below a set point. When setting up the laser system for the first time, NG CEO recommends testing the flow interlock before firing. Turn the eDrive on without current applied to the laser, and then turn the chiller off. A coolant interlock fault should appear on the screen. By testing the interlock with no current to the laser, there is no risk of damaging the laser.



NOTE: The chiller must run continuously to prevent biological growth or corrosion. If the laser system is to be shut down for more than 1 week, the laser system should be drained and the coolant loop purged with oil-free, dry filtered air or (N₂) per the “Prepare for Shipment” section of this manual.



WARNING. Do not operate the coolant system below air condensation temperature (dew point) at the laser head. Condensation on the diode arrays can seriously damage the laser head and will void the warranty. Consult NG CEO technical service if you have any questions.

Air Condensation Temperature

The air condensation temperature (or dew point) is the highest surface temperature that allows water to form from the ambient water vapor. The dew point is dependent on the surrounding air temperature and relative humidity. If a surface (such as a laser diode) is cooled at or below the condensation temperature, water may collect on that surface. A formula for calculating dew point is given below, along with a calculated table. All temperatures are given in Celsius.

Condensation Temperature

$$T_d = \frac{237.7 \times \alpha(T, RH)}{17.27 - \alpha(T, RH)} \quad \text{where} \quad \alpha(T, RH) = \frac{17.27 \times T}{237.7 + T} + \ln\left(\frac{RH}{100}\right)$$

T is the ambient air temperature in degrees Celsius ($0 < T < 60$)

RH is the relative humidity in percent ($1\% < RH < 100\%$)

T_d is the air condensation temperature

For example, suppose your chiller is running at 22 °C and the ambient air temperature near the laser is 28 °C (82 °F). Referring to Figure 3-4 and Table 3-4, find the intersection of the 28 °C air temperature and the curve for the 22 °C diode temperature. At a relative humidity of 70 percent or greater, condensation will form on the laser diodes.

Controlling the humidity level inside the laser is important to extend the lifetime of SHG crystal. The desiccant cartridge on the top cover can help to remove excess moisture from inside the laser head.



WARNING. Do not operate the laser without a functional desiccant cartridge. Condensation on the diode arrays can seriously damage the laser and may void warranty.

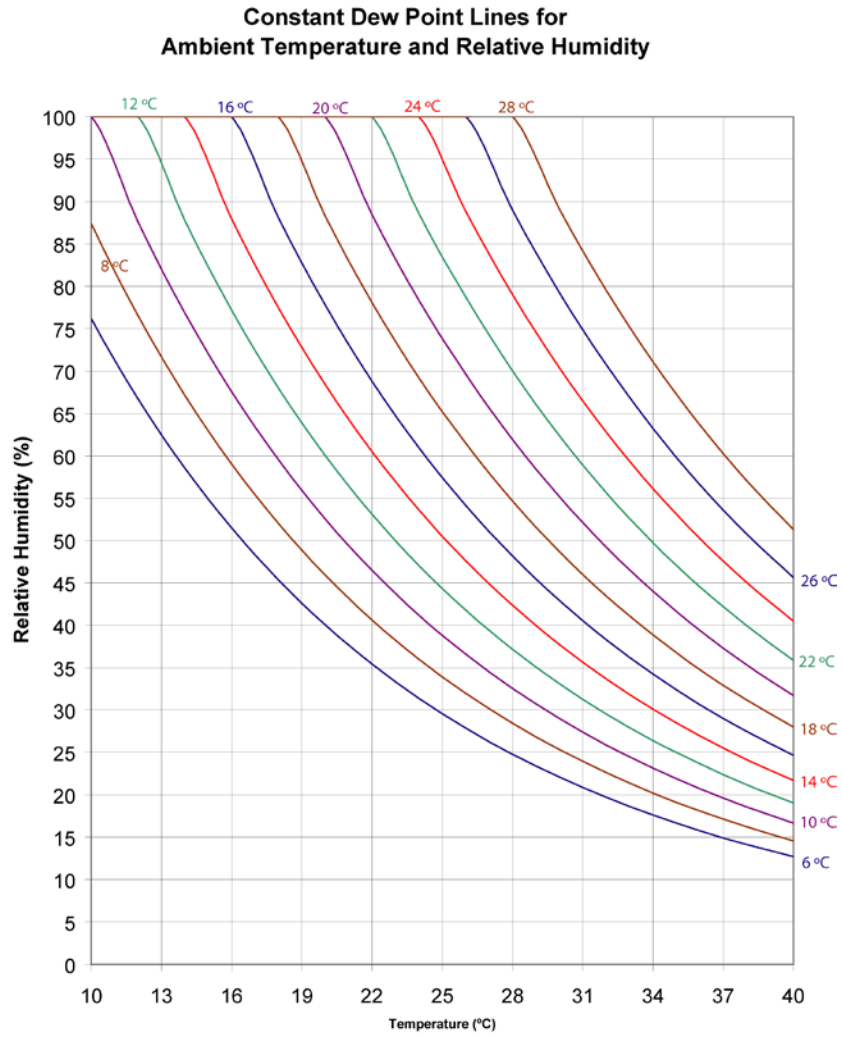

Figure 3-4 Constant Dew Point Lines for Ambient Temperature and Relative Humidity

Table 3-4. Table of Air Condensation Temperature at Given Ambient Air Temperature (Celsius) and Relative Humidity (percent)

		Relative Humidity										
		1%	10%	20%	30%	40%	50%	60%	70%	80%	90%	100%
Air Temperature °C	10	-43.9	-20.2	-11.9	-6.8	-3.0	0.1	2.6	4.8	6.7	8.4	10.0
	12	-42.6	-18.7	-10.3	-5.0	-1.2	1.9	4.5	6.7	8.7	10.4	12.0
	14	-41.4	-17.1	-8.6	-3.3	0.6	3.7	6.4	8.6	10.6	12.4	14.0
	16	-40.2	-15.6	-7.0	-1.6	2.4	5.6	8.2	10.5	12.5	14.4	16.0
	18	-39.0	-14.1	-5.3	0.2	4.2	7.4	10.1	12.4	14.5	16.3	18.0
	20	-37.8	-12.5	-3.6	1.9	6.0	9.3	12.0	14.4	16.4	18.3	20.0
	22	-36.6	-11.0	-2.0	3.6	7.8	11.1	13.9	16.3	18.4	20.3	22.0
	24	-35.4	-9.5	-0.4	5.3	9.6	12.9	15.7	18.2	20.3	22.3	24.0
	26	-34.2	-8.0	1.3	7.1	11.3	14.8	17.6	20.1	22.3	24.2	26.0
	28	-33.0	-6.5	2.9	8.8	13.1	16.6	19.5	22.0	24.2	26.2	28.0
	30	-31.8	-4.9	4.6	10.5	14.9	18.4	21.4	23.9	26.2	28.2	30.0
	32	-30.6	-3.4	6.2	12.2	16.7	20.3	23.2	25.8	28.1	30.1	32.0
	34	-29.5	-1.9	7.8	13.9	18.5	22.1	25.1	27.7	30.0	32.1	34.0
	36	-28.3	-0.4	9.5	15.7	20.2	23.9	27.0	29.6	32.0	34.1	36.0
	38	-27.1	1.1	11.1	17.4	22.0	25.7	28.9	31.6	33.9	36.1	38.0
	40	-26.0	2.6	12.7	19.1	23.8	27.6	30.7	33.5	35.9	38.0	40.0

If required to operate a laser in conditions near to the condensation temperature, take precautions to keep the laser dry. The laser should be operated inside an area that is purged with nitrogen (N₂) or encased in a sealed enclosure with a desiccant.

eDrive Nitro

The eDrive Nitro is a menu driven diode driver and laser controller. The eDrive Nitro regulates the diode drive current, controls the acousto-optic (AO) Q-switch pulses, and monitors the various interlocks. The front panel provides an emergency stop button to halt laser output.



WARNING: The emergency stop should only be used in an emergency situation. For normal operation use the shutter or emission buttons to halt laser output.

Additional information about the eDrive Nitro can be found in the eDrive User Manual.

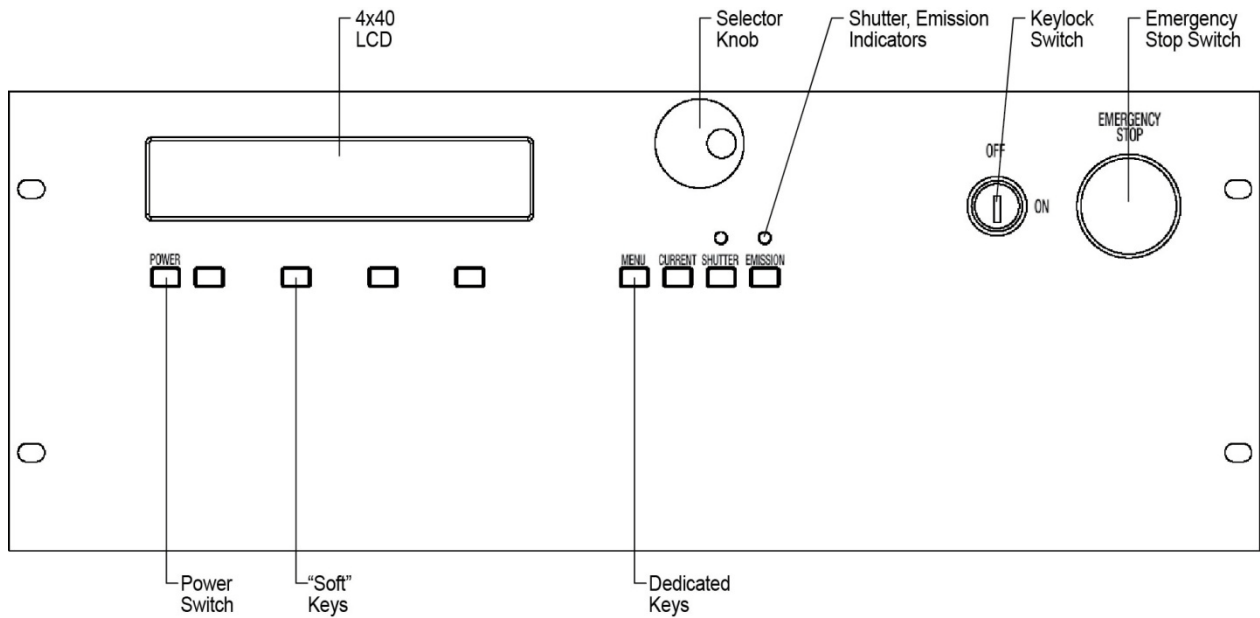

Figure 3-5. eDrive Nitro Control Panel

Chapter 4: Installation and Operation

To ensure safe operation of the Patara-IR TEM₀₀ laser system, please read the Chiller User Manual, and eDrive User Manual

This chapter covers:

- Laser system components
- Unpacking the laser system
- Laser head setup
- eDrive setup
- Chiller setup
- Connecting the chiller
- PolyScience 6000 series power-up procedure as example
- First Time Laser Power-up procedure
- Daily operation
- Adjusting the Laser System
- External Triggering and FPS

The purchaser is responsible for any loss and injury during installation and use of the laser system. NG CEO recommends that a qualified service technician install and maintain the laser. If you intend to service the laser yourself, please follow the following procedures.

Laser System Components

Before installing the laser, be familiar with the components of the laser system (see Figure 4-1).



Figure 4-1 Components for the Patara-IR TEM₀₀ Laser

Unpacking the Laser System

Your NG CEO Patara-IR TEM₀₀ laser was carefully packed for shipment. If its carton appears to have been damaged in transit, have the shipper’s agent present when you unpack.

Inspect the unit as you unpack it, looking for dents, scratches, or other evidence of damage. If you discover any damage, immediately file a claim against the carrier and

notify NG CEO technical service. NG CEO will arrange for repair without waiting for settlement of your claim.

Keep the shipping container. If you file a damage claim, you may need it to demonstrate that the damage occurred as a result of shipping. If you need to return the unit for service, the specially designed carton assures adequate protection.

A standard Patara-IR TEM₀₀ laser system consists of:

PA-020-QTIP
PA-020-QTIP Laser Head
eDrive, P/N ED4C-AXA-2440N
120V Single Phase 60 Hz Chiller P/N 6362T31CE20C
OR
208-230V Single Phase 50/60 Hz Chiller P/N 6352T41CE30E
Laser Signal Cable
RF Cables
Hoses and Filter for Chiller
Power Cord for Chiller
Power Cord for eDrive
Desiccant Cartridge

Please check the contents against the packing list and the sales order.

Laser Head Setup

The laser head should be mounted on an optical table or equivalent strong flat surface. There are three mounting holes provided to secure the laser. The laser should be installed in a clean environment.

In the direction of the laser output beam, a power meter with the power scale up to 30W should be installed approximately 1.5 feet away from the laser. In order to protect the power meter, a negative lens ($f=-100\text{mm}$) with AR coating at 1064nm should be installed in front of the power meter as shown in Figure. If a negative lens is not available, the power meter should be at least 2m away from the laser so that the beam size is larger and the power density is below the damage threshold of the power meter.

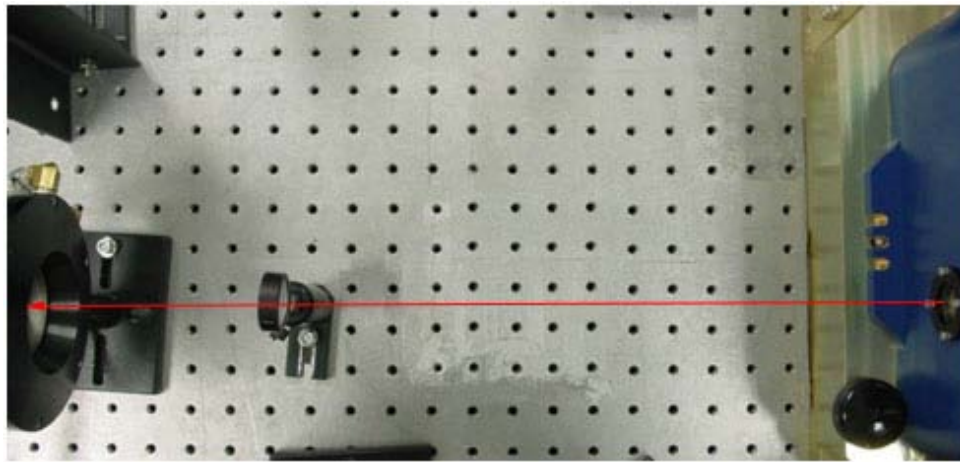

Figure 4-2. Basic setup for the laser power test

eDrive Setup

Input Power

Use only power cords suitable for your driver. Use a power source that delivers voltage in the range of 100 VAC (RMS) to 240 VAC (RMS) and 47 Hz to 63 Hz. Power switching is performed automatically (i.e., there are no configuration switches to set for high or low voltage ranging). Table 4-1 provides recommended fuse selection for each voltage range.

Table 4-1. Recommended Fuse Ratings

AC Input		Frequency	Fuse Ratings (F1, F2)
120V \pm 10%	15A	50/60 Hz	T 15A 250V
240V \pm 10%	8A	50/60 Hz	T 8A 250V

Fuse Dimensions: 0.25 x 1.25 inches

Mounting

The front panel of the eDrive is designed with four holes to mount into an EIA-310D-compliant rack. If this option is used, the eDrive's weight requires you use extra side supports. If the eDrive is to be used on a desktop or table top, it is recommended that the eDrive be equipped with feet to prevent the driver from marring the surface when it is moved. The eDrive must be secured.

Clearance

Adequate clearance should be allowed on the front, sides, and rear of the eDrive for access to connections and components. The front and rear vents of the eDrive must be a minimum of 24 inches (61 cm) away from walls or vertical surfaces so air flow is not restricted.

Chiller Setup

Ambient Temperature and Relative Humidity

The chiller is designed for indoor installation in ambient temperatures between 5 °C and 30 °C (41 °F and 86 °F). Relative humidity should not exceed 80 percent (non-condensing).

Location

The Chiller should be installed on a strong, level surface and be located as close to possible to the laser. It should not be installed closer than 4 feet (1.4 meters) to a heat generating source, such as heating pipes or boilers. If possible, the chiller should be located near a suitable drain to prevent flooding in the event of leaks. Do not place it where corrosive fumes, excessive moisture or dust, or high room temperatures are present.

For ease of positioning and maneuverability, the chiller is supplied with casters. The front wheels can be locked to keep the chiller in place while in use. To help prevent voltage drops, position the chiller as close as possible to the power distribution panel. Avoid voltage drops by using a properly grounded power outlet wired with 14 gauge or larger diameter wire. The use of an extension cord is not recommended



NOTE: The chiller may be located at a level below that of the equipment being cooled. As long as the process remains closed, overflow will not occur when adding cooling fluid to the chiller reservoir.

Oxygen Depletion Risk

In the event of a refrigerant leak, refrigerant gas may displace oxygen that could result in suffocation and death. Never place the chiller in a room that is smaller than the minimum room volume requirement as defined below. If the room is ventilated, the air distribution system must be analyzed to determine the worst case distribution of leaked refrigerant. A leak detector alarm device is always required in a ventilated room that does not meet the minimum room volume given below. Assure adequate and sufficient room volume and ventilation before placing a chiller that contains refrigerant in a room. Contact Polyscience at 800-229-7569 if you have any concerns or questions.

Pounds of refrigerant charge can be read directly from the nameplate on your chiller. Remember to include in your calculation any refrigerant that may be stored in any other containers.

Minimum Room Volume = Pounds of refrigerant x 110 cubic feet

Example: Two chillers are placed in a room, each containing 6 pounds of refrigerant. The minimum room volume shall be 12 x 110 cubic feet, or 1,320 cubic feet.

Clearance

Adequate clearance should be allowed on the front, sides, and rear of the chiller for access to connections and components. The cabinet of the chiller is designed to vent air. Maintain free space, equal to the height of the chiller, for flow of air on the condenser side of the chiller (opposite to where the coolant lines connect). The two sides or the top must have an equal amount of free space. When air flow becomes impeded, cooling capacity decreases and electrical efficiency drops as motor load increases.

Electrical Power

An IEC power cord is provided with the Chiller. It should be attached to the receptacle on the rear of the enclosure. Make sure that the power outlet used for the Chiller is properly grounded and matches the voltage and frequency indicated on the identification label on the back of the Chiller.

For 208-230V/60 Hz Polyscience chillers with less than 1.5 horsepower, the supplied power cord will be for connection to a NEMA 6-20 (North America) receptacle, in accordance with local electrical codes. A Euro cord will be supplied with 50Hz models.

The use of an extension cord is not recommended. However, if one is necessary, it must be properly grounded and capable of handling the total wattage of the unit. The extension cord must not cause more than a 10% drop in voltage to the Chiller.



CAUTION. The chiller has been set 208-230 Volts at the factory for 60-Hertz single phase or 200 volts for 50-Hertz single phase. High voltages out of the specified range could damage the chiller.



WARNING. DO NOT plug the Chiller into the electrical outlet until the unit is ready for Startup.

Chiller Cleaning Procedures

Please follow the proper procedures to clean the chiller before it is connected to the laser head. Refer to section “Clean and Maintain Chiller” in *Chapter 5: Maintenance* for details. Chiller maintenance procedures are also available through the NG CEO Knowledge Center.



WARNING. Make sure that the chiller will not contaminate the laser head.

Connecting the Chiller

Coolant Hoses and Filter Connections

The required coolant hoses, filters, and fittings are included in the plumbing kit that was shipped with your laser. They should be connected as illustrated in Figure 4-3. The correct coolant flow path starts with the supply port of the chiller ▶ filter ▶ coolant in port of laser head ▶ laser head ▶ coolant out port of laser head ▶ return port of the chiller. Please be aware of the flow direction of the filter.



Figure 4-3. Coolant Hoses and Filter Connections

The filter may be attached to the back of the chiller, customer's equipment or a wall using the provided L-bracket.



NOTE: Threaded hose barbs and adapters should have threads wrapped 3-4 times with Teflon tape.

Figure 4-4 depicts the chiller with connected coolant hoses.



Figure 4-4. Chiller Assembled with Coolant Hoses and Filter

Connections on Laser Head

Figure 4-5 depicts the connectors on the rear panel of the Patara-IR TEM₀₀ laser. All of the connectors are clearly labeled.



Figure 4-5 Connectors on the rear panel of the Patara-IR TEM₀₀ laser

1. **Plumbing Connection:** Push the barb fittings of coolant hose connectors gently into the **COOLANT IN** and **COOLANT OUT** ports by following the flow patch direction. Wetting the o-rings of the quick disconnect fittings and receptacles can prevent the o-ring from being cut by the mating piece during insertion. Make sure that the quick disconnect fittings are locked. A click is heard once it is locked.



Figure 4-6. Plumbing Connection

2. **Signal Connection:** Align the female connector of the laser signal cable to the **J1** connector on the laser head. Once it is aligned, the connector can be pushed in. Turn the locking ring of the connector in the clockwise direction until it is locked.



Figure 4-7. Signal Connection

3. **Diode Power Connection:** Connect the female connector of the diode power cable to the **J2** connector on the laser head.



Figure 4-8. Diode Power Connection

4. **RF Connection:** Connect the Q-switch RF cables to the BNC connectors on the laser head accordingly. The connector should be locked as well by turning it clockwise until it stops.

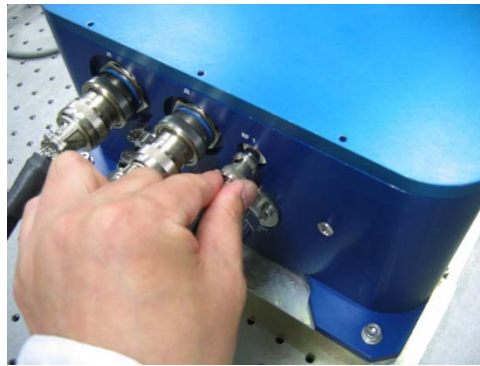

Figure 4-9. RF Connection

Connections on eDrive

1. **Laser Signal Connection:** Connect the male connector of laser signal cable to the receptacle labeled **LASER INTERFACE** on the back of eDrive.



Figure 4-10 Laser Signal Cable

2. **Diode Power Connection:** Connect the male connector of the diodes power cable to the receptacle labeled **ARRAY POWER** on the back of the eDrive



Figure 4-11 Diode Power Cable

3. **RF Signal Connection:** Connect the QS RF cables to the **RF OUT 1** connectors as shown below.



Figure 4-12 RF Signal Cables

4. **Chiller Interlock Connection:** Connect the 9 pin chiller interlock shorting connector as shown below.



Figure 4-13 Chiller Interlock Connector

5. **White Interlock Connection:** Connect the 2 pin white interlock shorting connector as shown below.

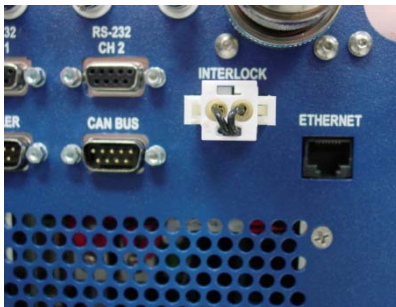

Figure 4-14 White Interlock Connectors

6. **Interlock Shorting BNC Connection:** Connect the 3 BNC shorting connectors to **TRIGGER/GATE IN**, **QSW THERM INTLK**, and **INTERLOCK** as shown below.



Figure 4-15 BNC Interlock Connection

PolyScience 6000 Series Power-Up Procedure

Usually NG CEO supplies the chiller with the laser. If customer purchases the chiller by themselves, the chiller has to be cleaned properly per manufacture's instruction before it is connected to the laser head.

Assuming the coolant hose, filter and laser head are properly connected, the following steps indicate how to turn on the cleaned PolyScience 6000 series for the first time.

1. Fill the reservoir. Remove the filler cap from the reservoir and, using a funnel, add fill the reservoir with a mixture of 10% Optishield Plus and distilled water until it reaches the MAX line on the reservoir's fluid level gauge. When full, remove the funnel, but do not replace the cap at this time.



WARNING. Do not use untreated de-ionized water in the system as it is aggressive in nature and can attack and corrode the metals in the laser head.

2. Connect the electrical power. Plug the chiller's power cord into an appropriate electrical outlet. Place the **Circuit Breaker/Power Switch** on the rear of the instrument enclosure to the **On** position. Three decimal points appear on the temperature display; two decimal points appear on the pressure/flow rate display.
3. Start process fluid flow. Press the **Power** button on the front panel. The system startup sequence begins. The pump turns on and fluid begins circulating through the system. The set point temperature appears briefly on the temperature display. After a few seconds, it will be replaced by the actual fluid temperature. The compressor will begin operating 15 to 20 seconds after power up.
4. Check for leaks. Once the pump is turned on, check all of the connectors to see if there is any leakage. If leakage is observed, turn off the pump immediately and fix the leak. The reservoir's fluid level will drop as the process and/or process cooling lines fill with fluid. Slowly add fluid to the reservoir until the liquid level remains stable.

5. Replace reservoir cap.

First Time Laser Power-Up Procedure

Remove the cap that protects laser output window and make sure the window is clean. If not, gently clean it with a lens tissue and methanol.

Verify Chiller Settings

1. Turn on the chiller.
2. Check the temperature setting of the chiller. Refer to the ATP test report data summary included in your Patara-IR TEM₀₀ laser shipment for the coolant operational temperature. The chiller's temperature setting should be the same as in the report. If it is set to a different temperature, change it to match the setting on the report.
3. The flow rate for Patara-IR TEM₀₀ laser is 1.5 GPM. Ensure the flow rate meets the requirement. If it does not, open the valve inside the chiller until it matches the flow rate recorded in the ATP test report data summary. When adjusting and setting the flow rate, do not allow the coolant pressure to exceed 70 psi.



NOTE. Chiller flow rate calibration may be required. Please refer to the chiller user manual for instructions on calibration.

4. Run the chiller for approximately ½ hour to allow the coolant temperature to stabilize at the set point.

Turn on and check the eDrive settings



WARNING. Read the eDrive user's manual to be familiar with safety precautions, functions, and settings.

1. Flip the power switch on the back panel of the eDrive to the **ON** or **I** position
2. Make sure that the red **EMERGENCY** button is released. Turn on the eDrive by turning the key to **ON** position and pressing the **POWER** button to power up the eDrive.
3. Check all other laser parameters in the eDrive Nitro. The menu designations will help locate the settings. Use the following values for the Patara-IR TEM₀₀ laser:

Table 4-2 eDrive settings

Menu 1	Menu 2	Menu 3	Parameter	Setting or Value
Channel Setup			Internal Trigger	Enabled
Channel Setup	Q-Switch		Q Switch (QS)	Enabled
			Set Frequency	refer to ATP test report
			Set Window Width	5 μ s
			Set Q-Switch Power	100%
Channel Setup	Q-Switch	Set FPS Settings	FPS	Enabled
			FPS Mode	Standard
			FPS Delay	refer to ATP test report
			Start Power	refer to ATP test report
			FPS Window Length	refer to ATP test report
			FPS Modulation Type	refer to ATP test report
			PPK Open Offset	0
			PPK Closed Offset	0
Channel Setup	Channel 1		Channel 1	Enabled
			Set Current	refer to ATP test report
			Set Standby Current	refer to ATP test report
			Set Slew Rate	refer to ATP test report
			Slew Control	Enabled
			Set Current Limit	refer to ATP test report
Channel Setup	Channel 1	Fault Setup	Set Voltage Dropout	20 V
			Set Current Tolerance	Enabled
			Set Current Tolerance	4 A
Interface Setup	Set Trig Out Mode		Trig out mode	QSW Active High
Interface Setup	Shutter Setup		Shutter FPS	Enabled
			Shutter Speed	14 ms
			Closed to Standby	Enabled
Interface Setup	Marking Mode Setup		LM Active	Low
			Gate Active	High
			FPS Active	High
Utility Functions			Manual Lockout	Disabled

- Verify that there are no objects in the laser beam path except for the negative lens and power meter.



WARNING. Wear proper laser safety eyewear to protect your eyes.

5. Once all the parameters are set correctly, and temperatures is stabilized, set the current to 10 A and press the **EMISSION** button.
6. Press the **SHUTTER** button to open the laser shutter. Gradually increase the current up to slightly above the threshold. Move the negative lens and power meter so that the beam is going through the center of the lens and hitting the center of the power meter.
7. Gradually increase the current set point to the operating current specified in the ATP test report. Don't touch any part of the laser and wait for the laser to stabilize for 1 hour (usually the laser takes around 20 minutes to reach 95% of the maximum power). Then check if the power is close to the result on the test report.
8. Usually the laser needs optimization for the first installation due to the slight differences of environments, chiller settings and vibration of the transportation. If so, please follow the laser performances optimization procedures in *Chapter 5: Maintenance*.

Daily Operation

Output energy and repetition rate of the Patara-IR TEM₀₀ laser system are adjustable over a wide range. However, operating protocols must be observed to assure operation without risking internal damage to optical components.



CAUTION. The output beam of this system is a safety hazard. Avoid viewing the beam directly.

Turn On Procedure

1. Switch the chiller to the **ON** position. Verify correct flow rate and temperature setting to value specified on laser ATP test report data summary. Wait until the chiller has achieved proper temperature, which may take 5 to 10 minutes.
2. Turn the eDrive power enable key switch to the **ON** position.
3. Press the eDrive **POWER** switch. LCD panel illuminates.
4. Press **MENU** to verify the current and Q-switch settings.



NOTE: Make sure the eDrive trigger signals are properly set if the laser uses external triggering.

5. Check and set the operational current.

6. Press **EMISSION** to fire the laser diode. The **EMISSION** and **LASER ON** indicators will begin to blink.
7. Press the **SHUTTER** button. The **EMISSION** and **LASER ON** indicators will become steady. The laser will automatically ramp the current to the set point with the preset slew rate. Wait for about 20 minutes to reach 95 percent of nominal output power.

Manual Interrupt Procedure

1. Press **SHUTTER** button on the eDrive front panel. The button will blink indicating the shutter is closed and the current is reduced to the standby current level.
2. Resume operation by pressing **SHUTTER** again. The laser will resume operation with no audible warning and the button will be illuminated.



NOTE: The laser diodes are operated at set standby current while the shutter is closed.

Interlock Interrupt

There is an interlock connector (white) at back panel of eDrive. If the continuity of the interlock is broken, the laser will stop lasing by closing the shutter and decreasing the current to standby. Once the continuity of the interlock is satisfied, the laser will ramp up the power automatically. For other interlock configurations, please contact NG CEO.



CAUTION. Never look at the laser beam even it is off because the laser beam will ramp up the power automatically.

Shut Down Procedure

1. Press **SHUTTER** button to stop lasing.
2. Gradually decrease operating current to zero.
3. Press **EMISSION** on the eDrive to cease diode emission.
4. Press and hold **POWER** on the eDrive for 5 seconds until the display turns dark.
5. Turn the eDrive power enable key switch to **OFF**.
6. Let chiller run for 1 to 2 minutes.
7. Turn off the chiller.

For detailed operating instructions, please refer the eDrive User Manual

Adjusting the Laser System



WARNING. The Shutter must be closed before adjusting the PRF. Adjusting the PRF while the laser is operational may result in optical damage.

Change the PRF

1. Press **SHUTTER** button to stop lasing. The button will blink indicating the shutter is closed and the current is reduced to the standby current level.
2. See the ATP test report data summary for the maximum current setting associated with PRF
3. Change the eDrive current setting. Refer to Table 4-4 eDrive Settings and parameter “Set Current”
4. Change the eDrive PRF. Refer to Table 4-4 eDrive Settings and parameter “Set Frequency”
5. Change the FPS settings. Refer to Table 4-4 eDrive Settings and parameter “FPS Delay”, “Start Power”, “FPS Window Length” and “FPS Modulation Type”. For additional FPS information refer to *External Trigger and FPS* in this chapter.
6. Resume operation by pressing **SHUTTER** again. The laser will resume operation with no audible warning and the button will be illuminated.
7. Warm up for one hour (not necessary if laser has been operating)
8. Optimize laser per the Optimize Laser Performance section in *Chapter 5: Maintenance*
 - Fine Tune Cavity Mirrors



NOTE: For lasers with more than 1000 hours of operation, diode current and cooling fluid temperature may need to be optimized as well.

External Triggering and FPS

The laser may be externally triggered using a TTL signal of 300 ns to 500 ns duration. The signal may be input via the BNC connector labeled **EXTERNAL TRIGGER** on the back of the eDrive controller.

Figure 4-27 illustrates the RF signal output to the Q-switch without first pulse suppression (FPS) and the laser pulse train with the first giant pulse. If the peak power of these giant pulses is high enough, it can cause the damage to the mirrors and the laser crystals. The giant pulse forms when the lasing was stopped while the pumping light is still on during the laser processing cycle. The amplitude of the giant pulse is dependent on the non-lasing duration as well as the operating current.

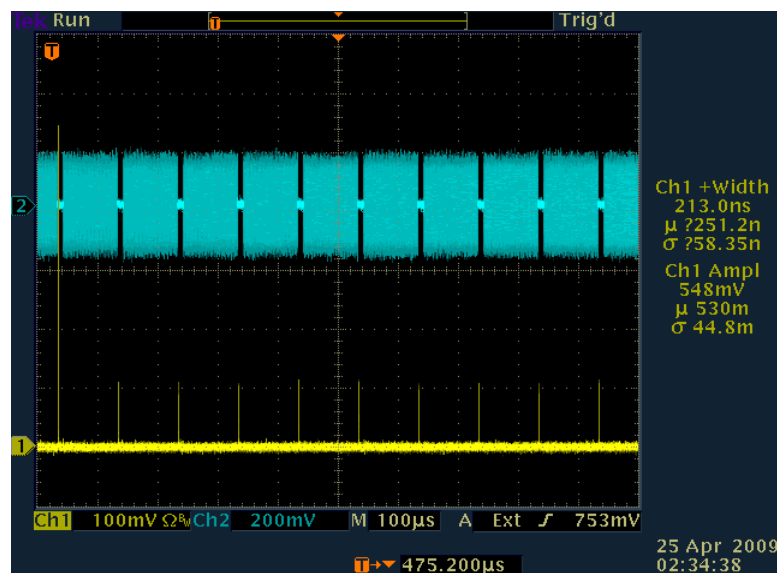

Figure 4-27. First Giant Pulse with FPS Disabled



CAUTION. The FPS has to be enabled and parameters for FPS have to be set properly. Failure to suppress the first giant pulse may cause the internal optical damage as well as damage to the work piece.

For each type of laser processing, a particular operating current and pulse repetition rate are needed. The giant pulse can be suppressed by enabling FPS and setting the proper FPS parameters. For detailed information, please refer the *Configuring the Integrated AO Q-Switch RF Driver* section in *Chapter 3: Operating Basics* in the eDrive User Manual.

To set the FPS properly, use a photodiode detect with response time 1 ns and an oscilloscope.

Chapter 5: Maintenance

The chapter contains information in these sections:

- Prepare for shipment
- Purge housing
- Replace desiccant cartridge
- Clean and Maintain chiller
- Check hold off
- Extend lifetime of laser diodes
- Optimize laser performance

Prepare for Shipment

It is anticipated that in OEM applications the Patara-IR TEM₀₀ laser will be installed in another system that will be shipped internationally. The Patara-IR TEM₀₀ optical assembly must be properly prepared for shipment if internal damage is to be avoided due to possible freezing of coolant trapped in the lines. This procedure follows:

1. Ready a dry gas source in preparation for draining the system. Oil-free, dry filtered air or (N₂) is recommended.
2. Remove coolant connections from back of laser housing.
3. Connect a dry gas line to the **Coolant Out** connector on the housing. Coolant lines must be purged in the proper direction or trapped coolant may remain in the lines inside the laser. If this trapped coolant freezes it can cause lines to leak when operation is resumed.
4. Connect a drain hose with a proper quick disconnect fitting to the **Coolant in** connector on the housing.
5. Purge the lines with for at least ½ hour at 5 psi.
6. Remove purge lines.

After the laser is dry place it in a sealed ESD bag with a desiccant. Package the laser securely in a shipping container.

You will need to remove all coolant from the chiller prior to shipment. Refer to the chiller manufacturer's instructions. Do not reconnect chiller lines to laser prior to shipment. After shipment, if antifreeze was used, drain and clean the chiller. Add a new filter and clean Optishield Plus coolant before reconnecting the chiller to the laser.

Purge Housing

The Patara-IR TEM₀₀ optics assembly must be kept at low humidity to prevent the possibility of condensation on the laser diode arrays. The Patara-IR TEM₀₀ housing provides a level of protection from entry of ambient humidity, but it is not hermetically sealed. When operating in a high ambient humidity, precautions need to be taken to keep the interior of the housing dry. The lid of the housing has a port for a desiccant cartridge, which should be changed when the cartridge indicator is no longer blue. Also, the housing interior can be purged with clean, dry air using the valve on the rear of the housing. The inlet line is the stemmed valve and is opened and closed by rotating the knob on the valve end. Please contact NG CEO before attempting this procedure.



CAUTION. The clean dry air input line must be on a pressure regulator and the line must be filtered.

Replace Desiccant Cartridge

The desiccant cartridge removes excess moisture from inside the laser head. It is located on the lid of the Patara-IR TEM₀₀ laser head. The desiccant cartridge must be replaced regularly, so it should be checked at least weekly for exhaustion.

Exhaustion is indicated by a change in the color of the indicator paper in the top of the cartridge. While any sector of the indicator paper in the cartridge top remains blue, the cartridge can still absorb water. When all sectors of the indicator paper turn completely white or light pink, the cartridge has absorbed all the water it can and must be replaced. Replacement frequency varies with the humidity in your operating environment and if the laser head is opened.



WARNING Waiting to replace desiccant until all sectors on desiccant cartridge have turned white will result in optical damage.

If the desiccant cartridges are exhausted in a short time frame (e.g., two weeks) without the laser head having been opened, contact NG CEO technical service.

A second desiccant cartridge is recommended to reduce the time the desiccant cartridge is removed from the Patara-IR TEM₀₀ laser cover during service. Any spare desiccators should be stored in a cool dry area. A nitrogen purged dry box is recommended for storage.

Two types of desiccant cartridges are used in Patara-IR TEM₀₀ lasers depending on the build date.

40 Gram Desiccant Cartridge

The 40 Gram Desiccant cartridge (Figures 5-1 and 5-2) is used on Patara-IR TEM₀₀ lasers built November 2013 and later.

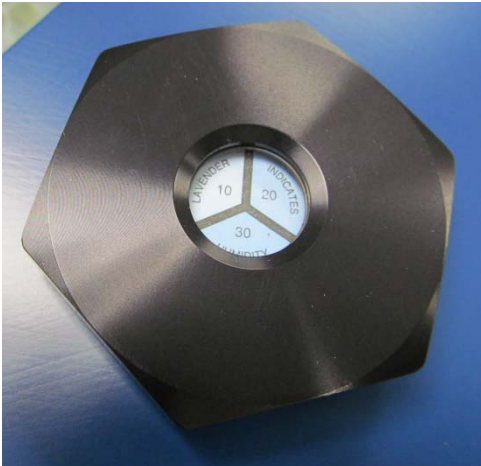

Figure 5-1 40 Gram Desiccant Cartridge Top

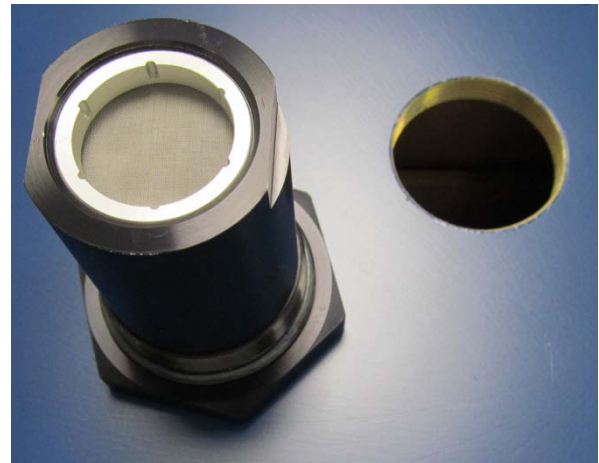

Figure 5-2 40 Gram Desiccant Cartridge Bottom

To service the desiccant, the following supplies are required. Desiccant supplies can be purchased from NG CEO, or directly from AGM Container Controls, Inc. telephone number 800-995-5590.

- Desiccant cartridge NG CEO part no. 42-228
- Refill part number 643665
- Refill tool 980412

Remove the desiccant cartridge from the top cover of the laser housing. Use the refill tool to remove the retainer ring, and exchange the desiccant. The refill package contains 50 grams of desiccant. Fill the cartridge to the surface that the filter rests on. Do not overfill.

Make sure that there are no desiccant beads on the surface that the filter rests on. Install the paper filter, then the screen, then the retainer ring. Hand-tighten the retainer ring with the refill tool. Replace the desiccant cartridge immediately to minimize the amount of time that the desiccant cartridge is removed from the laser housing.

Tighten the desiccant cartridge by hand. **DO NOT OVERTIGHTEN.**



Figure 5-3 50 Gram Refill and Refill Tool



WARNING. Do not operate the laser without a functional desiccant cartridge. Condensation on the diode arrays or other optics can seriously damage the laser and may void warranty.

Clean and Maintain Chiller

The 5 μm filter and coolant in the chiller should be replaced at least monthly. Comply with your chiller manufacturer's recommendation if more frequent. The color of the filter and coolant hose are pretty good indicators for the coolant quality. The coolant hose should be clear and the filter white. If not, the chiller needs maintenance. Drain and re-fill the chiller per the chiller and coolant manufacturer's instructions.

The chiller must run continuously to prevent biological growth or corrosion. If the laser system is to be shut down for more than 24 hours, the chiller should either left running or drained and the coolant loop purged with oil-free, dry filtered air or (N_2) per the "Prepare for Shipment" section of this manual.



NOTE: Dirty coolant will contaminate the Nd:YAG rod, which will impact the laser performance.

Chemicals and Supplies Needed

- 3% Hydrogen Peroxide solution sufficient to fill the system.
- Optishield Plus™ and distilled water solution (10% Optishield Plus™, 90% distilled water).
- Distilled water, sufficient to fill the system.
- Two replacement particle filters (NG CEO part # 37023165).

Cleaning Procedure

1. Drain chiller and clean any residue or contamination in the reservoir with the use of a bottle brush or alcohol wipes.
2. Using a filter housing wrench, dismantle the particle filter housing. Empty the coolant trapped in the filter housing into a container for later disposal.
3. Dispose of the expired particle filter and clean any residue or contamination from the inside of the filter housing. Install a new filter in the housing.
4. Refill with distilled water and circulate for 5 minutes.
5. Drain system completely as detailed in steps 1 and 2.
6. Fill the chiller with a 3% solution of Hydrogen Peroxide. Care should be taken to ensure that the mixture completely fills to the top of the reservoir to ensure all wetted surface areas of the chillers are cleaned. Cycle the chiller on and off. Top off the reservoir as necessary to ensure it is full of the cleaning solution. Ensure that the cap of the chiller reservoir is loose or remove it completely to allow gas to escape from the system.
7. Circulate the cleaning solution through the system including the laser module for 40 minutes.
8. Drain the cleaning solution mixture from the chiller as detailed in steps 1 and 2.
9. Refill and circulate distilled water for 5 minutes and drain. Ensure that the cap of the chiller reservoir is loose, or remove it completely to allow gas to escape from the system.
10. Drain the chiller and dispose of the filter.
11. Disconnect the chiller from the laser module and blow out water from the laser module coolant loop prior to refilling the chiller coolant reservoir.
12. Reconnect the laser module coolant loop.
13. Install new 5 micron filter into housing.
14. Record cleaning date on sticker with a one-month reminder to drain & clean the system. Affix sticker to chiller (or cabinet).
15. Refill the chiller reservoir with Optishield plus and distilled water coolant following the manufacturer's directions. Run for 30 minutes with the cap loose to allow gas to escape from the system.

16. Secure the reservoir cap.
17. The chiller is now ready to use.

Check Hold Off

Checking hold off is a technique needed to verify proper operation of the laser. To check hold off, perform the following steps:

1. Turn on the laser and run for at least 20 minutes.
2. Lower the current to 10 A.
3. Set the Q-switch (QSW) internal trigger (or external gate) mode to external trigger mode in the Channel Menu on the eDrive. Ensure there is no input to the external gate BNC on the rear panel of the eDrive. Refer to the “Pulsed Q-Switch Setup Menu” in the Standard Menus section of the eDrive user’s manual.
4. Gradually increase the current to the full operation current level.
5. Observe the beam output on the power meter. Hold off condition is met when no green light is visible.
6. If green is observed, the laser does not hold off and may need internal repair.
7. Reduce the current to 10 A.
8. Return the eDrive to internal trigger (or external gate) mode.
9. Gradually increase the current to the operation current.

Extend Lifetime of Laser Diodes

The specification for laser system optical output is provided in the ATP Test Report Data Summary delivered with the system. During its early lifetime, the laser diodes will deliver this specified power at or below the preset current limit. As the diodes age, an increase in current may be required to maintain power and beam quality so the diodes can continue to be used. Once the maximum current of 30 A is reached, consider replacing diodes or upgrade the laser. Please contact NG CEO for detailed information.

Optimize Laser Performance

Optimization of the laser may be required when the laser is initially installed or the laser performance has degraded due to aging laser diodes.

For this procedure, a green light should be visible from the laser. In the absence of any visible output, please review *Chapter 7: Troubleshooting* or contact NG CEO for

assistance. To obtain the best performance, small adjustments may optimize the laser. To optimize the laser, follow these steps:

1. Wait for the laser reach thermal stabilization.

Both the laser bench temperature and environmental temperature significantly impact the laser power. Wait for the laser to be thermally stabilized before attempting any adjustment.

2. Check the settings of the eDrive and chiller.

Check the performance with all items set to the values on the laser ATP test report data summary. Verify that all of the eDrive settings are correct.

The coolant flow rate and temperature have a significant impact on the laser performance. Make sure that the flow rate is approximately 1.5 GPM and the temperature of the chiller matches results from the original test report.

3. Peak the laser power by adjustment of chiller temperature.

The laser diode wavelength will slowly drift as the laser diodes age. In order to match the diode wavelength to the absorption wavelength of Nd:YAG crystal, the chiller temperature has to be adjusted. Chiller temperature adjustment should be stopped when the temperature may cause the condensation inside the laser.

4. Peak the laser power by increasing the current.

Figure 5-4 illustrates an example of the dependence of the output power of the Patara-IR TEM₀₀ laser to operating current. Notice that the laser power increases as the operating current is increased. The laser had maximum power around 24.5 A. The laser had slope efficiency of 4 W/A around the operating current. The power will change ~.4W by changing the current 0.1 A increments. The laser diodes have an aging rate less than 2% over 1,000 hours which means the laser would be considered normal if the power is maintained over 250 hours by increasing the operating current 0.1A.

The laser has an unstable zone, where the laser doesn't have stable output power due the cavity design and variable YAG thermal lensing. Therefore, it is suggested to use Q-switch power or use an external power attenuator to have desirable stable output power.

The slight difference between the actual operating current and the ATP test report value may be due to the performance difference of the chillers. An increase in the operating current or a change in chiller temperature can compensate for the aging of the Patara-IR TEM₀₀'s laser diodes. In order to protect the laser, the current limit of the eDrive is set at the maximum operating current. The limits need to be increased as the laser diodes age.

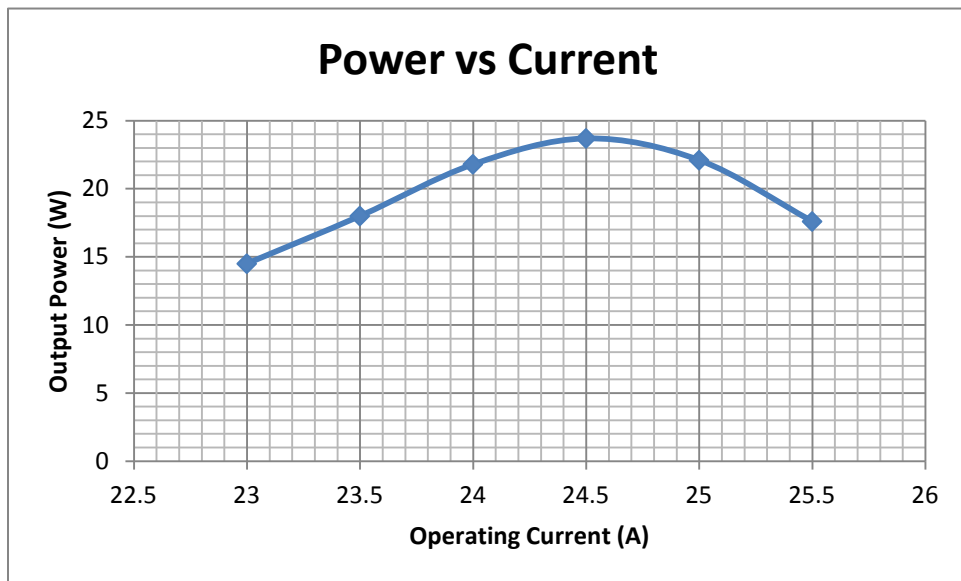

Figure 5-4 Example of Laser Performance Dependence on the Operating Current

5. Peak up the laser with adjustment of the cavity mirrors.



WARNING. Making mirror adjustments can be non-reversible. Do this step only when all the steps above have been completed and the laser does not meet the specifications with the correct settings.

- a. Locate the access holes for high-reflection (HR) and Output Coupler mirrors (OC). Notice the positions of HR and OC mirrors with respect to the direction of the laser output in Figure 5-5
- b. Remove screws from access holes only in a dust free environment.
- c. Use a 1/8 inch ball driver to make adjustments. A fine adjustment is a 1 degree or less rotation. A small adjustment is about a 2 degree rotation. A coarse adjustment is 15 degrees to 20 degrees rotation. If coarse adjustments are needed to obtain performance, reduce operating current by 1A. Return to normal operating current when making small and fine adjustments.
- d. The screws for the adjustments of the vertical tilt angle and the horizontal tilt angle are illustrated in Figure 5-5.

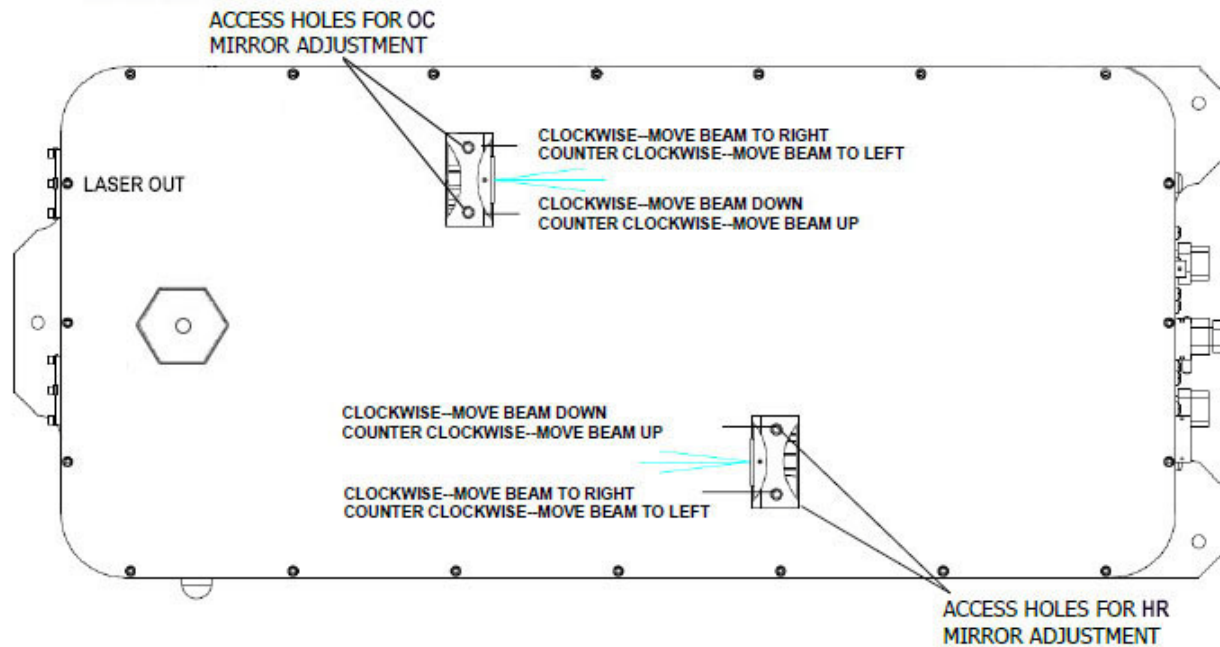

Figure 5-5 Accessible Holes for HR and OC Mirror Adjustment

e. Optimize power:

- Make small adjustments to the horizontal angle of HR mirror and observe the output power.
- Once a maximum is found, adjust the vertical control of HR mirror to maximize power.
- Make small adjustments to the horizontal angle of OC mirror and observe the output power.
- Once a maximum is found, adjust the vertical control of OC mirror to maximize power.
- Repeat the optimization steps with both the HR and OC until there is no significant performance improvement.
- If the laser is still not within 5% of the original power or not stable, repeat the eDrive current optimization, and HR / OC adjustment until there is no significant performance improvement.
- If the laser power can't be restored to the specification, or the laser is not stable, then the "walking the cavity" procedure can be tried. Walking the cavity is sometimes required to optimize the laser and involves combining mirror mount adjustments.
 - Reduce current by 1A while making coarse adjustments. Return current to normal when making fine adjustments.
 - Make a horizontal adjustment to the HR mount. Recover the laser power by making a similar adjustment to the horizontal control of the OC mount.

- Continue if improvement is noted. If there is no improvement, try the opposite direction.
- Perform the same procedure with the vertical adjustments of the HR and OC mount.
- Periodically check for hold off when making these adjustments (see *Check Hold Off* section in this chapter).
- If laser power is within +/-5 percent of nominal (typical power meter accuracy), and it has good beam shape and stability, stop and replace the access screws in the cover.

Chapter 6: Service

At Northrop Grumman Cutting Edge Optronics, we are proud of the durability of our products. Our manufacturing and quality control processes emphasize consistency, ruggedness, and high performance. Nevertheless, even the finest instruments break down occasionally. We believe that the reliability record of our instruments compares favorably with that of our competition, and we hope to demonstrate our superior service by providing dependable instruments and, if the need arises, service facilities that can restore your instrument to peak performance without delay.

When calling for service in the U.S., dial (636) 916-4900 (follow prompts for department directory). To phone for service in other countries, contact your sales agent.

This chapter provides reference to types of customer service needs:

- Contacting customer service
- Laser Module replacement
- Return the instrument for repair

Contacting Customer Service

To expedite your service needs, please complete the questionnaire in *Appendix A: Customer Service* **before** you contact NG CEO Technical Service. Complete the questionnaire with as much detail as possible and retain a copy for your records.

E-mail or fax the form to NG CEO (refer to the second page of this manual for contact information) and notify your customer service representative that it has been sent.

Laser Module Replacement

The laser module can be replaced by a trained service engineer. Contact NG CEO for Laser Level 2 training, and access to Level 2 maintenance instructions.

Return the Instrument for Repair

A return merchandise authorization (RMA) *is required* prior to shipping any instruments to NG CEO. Contact NG CEO or your local distributor for RMA and shipping instructions.



CAUTION. Failure to obtain proper shipping instructions may result in damage to the instrument.

Use the packing boxes supplied by NG CEO to ship your instruments. If shipping boxes have been lost or destroyed, replacements are available for a nominal charge from NG CEO.

Remove all coolant from laser prior to packaging for shipment (see *Chapter 5: Maintenance* for details). Place a desiccant in a sealed ESD bag with the laser and secure the laser in the shipping container.



WARNING. Damage from residual coolant due to condensation or expansion can be catastrophic to the diode arrays or laser rod if not dealt with properly. Such damage is excluded from warranty coverage.

Chapter 7: Troubleshooting

This chapter is intended to provide possible solutions to common problems encountered with the Patara-IR TEM₀₀ laser during normal use.



WARNING. Do not attempt repairs while the unit is under warranty. Complete the form in Appendix A and report problems to NG CEO for repair.

The following sections can be found in this chapter:

- Initial checklist
- Laser output power
- eDrive Operation

Initial Checklist

Before adjusting or attempting troubleshooting procedures, verify the following. Additional information is available in the troubleshooting guide that was supplied with your laser:

- Verify the eDrive is operating at the correct output current and the current set point matches the test data sheet supplied with the laser.
- Verify that the eDrive QSW power control is at 100 percent.
- Ensure that the Q-switch is enabled.
- Verify the Q-switch is set to “internal trigger” and to the frequency specified on the test data sheet.
- Verify the chiller set point temperature and flow rate are correct.
- Operate the laser and for at least 20 minutes to reach full power and stability before making any adjustments.

Only after verifying these conditions should you attempt to make adjustments to the laser system.

Laser Output Power

Low Output Power (0.01 W -full)

Low Q-switch power: Check the setting of the Q-switch power in the eDrive. Verify that it is set to 100 percent.

Problem with power meter: Use another power meter to verify the measurement.

Low operating current: Check the set current and actual current. A too high or low current setting will result in low power.

Coolant temperature not set: Verify the chiller is set to provide the correct coolant flow rate and temperature to the laser head.

Laser is running in CW mode or problem with hold off: Check the hold off of the laser, ensure the Q-switch is enabled, and the eDrive’s RF driver is functioning properly.

Pulse repetition rate is not correct: Check the pulse rate frequency (PRF) in eDrive or the frequency of trigger pulses.

Laser is misaligned: Perform the laser power optimization procedures as described in the *Optimize Laser Performance* section in *Chapter 5: Maintenance* to bring the power back.

Internal optical damage to the laser, contaminated rod, or aging diodes: If the laser power cannot be restored after optimization, contact NG CEO for service.

No Output Power

- Verify the operating current is set at the operation point.
- Verify the Q-switch is set to hold off and the laser is triggered at preset PRF with an internal or external triggering source.
- Verify the shutter light on the front panel of the eDrive is turned on indicating that laser shutter is open.
- Verify there are no interlock warning messages on the eDrive and that the eDrive is supplying the correct current.
- Verify the eDrive is not gated off externally and not commanded to low or 0 percent QSW power.

Laser Flicker

When the external perturbations are applied to the laser system, the laser exhibits flickering.

- Verify the laser performance is optimized.
- Verify there is no strong vibration forces applied to the laser head.
- Verify that the flow rate to the laser head is above 1.5 GPM and the coolant flow is not intermittent.
- Verify the laser has good output power. A laser with high modulation loss or low operating current is sensitive to perturbations.
- Verify the operating current is stable.
- Verify the Q-switch hold off is good.

eDrive Operation

The following issues may occur in relation to the Patara-IR TEM₀₀ laser.

CW Power Only, No Optical Pulsing

Perform initial check on system. CW power only or absent optical pulsing is typically caused by the wrong settings or an eDrive problem. Verify settings listed in *Chapter 4: Installation and Operation*, or refer to the eDrive User's Manual section on troubleshooting for procedures and details.

Hold Off Failure

Perform initial check on system. This problem can be Q-switch low power fault on the eDrive. Refer to the eDrive User's Manual section on troubleshooting for procedures and details.

Hold off failure can be caused by a failing QSW. This requires the internal laser be repaired.

Occasionally, a re-tuned laser can suffer from hold off loss. To remedy, change the angle of the QSW. Since QSW angle cannot be adjusted outside the laser, internal service will be required.

The eDrive has built-in diagnostics to alert the user of fault conditions. Common error reports and suggested remedies follow. Consult the eDrive User Manual for more details.

Chiller Fault Detected / Flow Interlock Fault

- Check chiller for operation and low coolant level.

Hardware Fault Detected

- Check that the Emergency Stop button is not depressed.
- Check **INTERLOCK** input on back panel for open condition.

Cover Interlock Fault Detected

- Verify that the cover is secure on the laser.
- Check cable connections to laser.

Q-Switch Driver Over-Temp Fault

- Verify the cooling fan for the RF driver is operational.
- Verify that the airflow through the driver is not obstructed. This fault will not clear until the RF driver has had time to cool down.

Q-Switch HVSWR Fault

- Check RF cable connection to laser.
- Perform RF output power check.

The Q-switch has failed if the measured RF power is around 25 W with 50 Ω RF dummy load. Contact NG CEO for repair.

Q-Switch Low Power Fault

- Perform RF output power check.
- Verify voltage to RF driver.
- Adjust RF power if needed.

Channel Over Temperature Fault

- Verify the eDrive fans are operational.
- Verify that the airflow through the driver is not obstructed.

A

Appendix A: Customer Service

This form has been provided to encourage you to tell us about any difficulties you may have experienced while using your NG CEO instruments or user manuals. Call or write our customer service department to bring attention to problems that you may not have personally experienced. We are always interested in improving our products and manuals, and we appreciate all suggestions.

Date:

Name:

Company or Institution:

Department:

Address:

Laser Model Number:	Serial Number:
Chiller Model Number:	Serial Number:
eDrive Model Number:	Serial Number:
Laser Manufacture Date:	Total Laser Lifetime (hours):

Questions

What is the coolant flow rate (GPM)?

What is the set temperature on the chiller (°C)?

What is the coolant pressure on chiller (PSI)?

What are the set current and actual current from eDrive (A)?

Is Q-switch enabled (yes/no)?

Is Q-switch triggered internally or externally?

What is the Q-switch power (percent)?

Is FPS enabled (yes/no)?

What are the FPS parameters?

What is the pulse repetition frequency (kHz)?

Is the output power measured directly from the laser (yes/no)?

What is the measured power (W)?

When did the problem happen?

Have you changed any settings recently (yes/no)?

Have you adjusted the laser to try to fix the problem (yes/no)?

What are the changes made recently to the system?

Please describe the problem or laser behavior as detailed as possible:

Suggestions

Email or fax to:
Northrop Grumman
Cutting Edge Optronics, Inc.
20 Point West Boulevard
Saint Charles, MO 63301 USA
Phone: (636) 916-4900
Fax: (636) 916-4994
Email: ngceoservice@ngc.com

Appendix B: System International Units

The following System International (SI) units, abbreviations, and prefixes are used throughout NG CEO user manuals:

Quantity	Unit	Symbol
mass	gram	g
length	meter	m
time	second	s
frequency	Hertz	Hz
force	Newton	N
energy	Joule	J
power	Watt	W
electric current	Ampere	A
electric charge	Coulomb	C
electric potential	Volt	V
resistance	ohm	Ω
inductance	Henry	H
magnetic flux	Weber	Wb
magnetic flux density	Tesla	T
luminous intensity	candela	cd
temperature	Kelvin	K

Abbrv.		Prefixes
tera	(10^{12})	T
giga	(10^9)	G
mega	(10^6)	M
kilo	(10^3)	k
deci	(10^{-1})	d
centi	(10^{-2})	c
milli	(10^{-3})	m
micro	(10^{-6})	μ
nano	(10^{-9})	n
pico	(10^{-12})	p
femto	(10^{-15})	f
atto	(10^{-18})	a

Appendix C: Acronyms

Acronym	Description
ACGIH	American Conference of Government Industrial Hygienists
ANSI	American National Standards Institute
AO	Acousto-optic
AR	Anti-Reflective
ATP	Acceptance Test Procedure
ASM	Array Sub-Module
CDRH	Center for Devices and Radiological Health
CEO	Cutting Edge Optronics, Incorporated
CFR	Code of Federal Regulations
CW	Continuous Wave
DC	Direct Current
EO	Electro-Optical (type of Q-switch)
ESD	Electro-Static Discharge
FET	First Pulse Suppression
FWHM	Full Width – Half Max
FPS	First Pulse Suppression
GaAlAs	Gallium Aluminum Arsenide
GPM	Gallon Per Minute
HeNe	Helium Neon
HM	Harmonic Mirror
HR	High-Reflection
IEC	International Electrotechnical Commission

Acronym	Description
IR	Infrared
KTP	Potassium Titanyl Phosphate
LPM	Liters Per Minute
LBO	Lithium Triborate
MCC	Meters Concave
N ₂	Nitrogen
Nd:YAG	Neodymium-Doped Yttrium Aluminum Garnet
Nd:YLF	Neodymium-doped Yttrium Lithium Fluoride
NG	Northrop Grumman
NIR	Near Infrared
OC	Output Coupler
OSHA	Occupational Safety and Health Administration
PRF	Pulse Rate Frequency
PSI	Pounds per Square Inch
QCW	Quasi-Continuous Wave
QSW	Q-switch
RF	Radio Frequency
RH	Relative Humidity
RMS	Root Mean Square
SHG	Second Harmonic Generator
TEC	Thermal Electric Cooler
TEM ₀₀	Transverse Electromagnetic Mode
TTL	Transistor - Transistor Logic
UV	Ultraviolet
VAC	Volts, Alternating Current

Index

A

ATP. See test report

B

BNC, **38, 45**

C

caution, **vi**
 chassis ground, **vi**
 chiller, **3, 4, 10, 13, 14, 15, 16, 20, 21, 25, 26, 27, 28, 32, 33, 35, 36, 39, 40, 43, 46, 53, 55, 57, 58**
 cleaning, **26**
 condensation, **15, 16, 18, 43**
 contacting Cutting Edge Optronics, **ii**
 coolant, **4, 5, 13, 40**
 cooling, **4, 14**
 Customer Service, **vii, viii, 50, 51, 57**

D

data summary. See test report
 desiccant, **16, 18, 39, 40, 41, 42, 43, 51**
 Diode, **29**

E

eDrive, **iii, viii, 3, 4, 5, 10, 15, 18, 19, 20, 21, 24, 30, 33, 35, 36, 38, 45, 46, 52, 53, 54, 55, 56, 57, 58**
 emergency stop, **18, 19**
 end-of-life handling, **iv**
 ESD, **v**
 EU directives, **iv**

F

filters, **27**
 fuse, **24**

G

ground
 chassis, **vi**

H

Hold Off, **45, 49, 55**

K

Knowledge Center, **ii, 26**

L

laser
 emission, **vi**
Laser Safety, **vii, viii, 6**

M

module, **44, 50, 51**

N

negative lens, **34**

O

optimize, **39, 45, 46, 48**
 optimization, **45, 48, 54**
 Optishield, **14, 32, 40**

P

plumbing, **14, 27**
 power meter, **34, 45, 49, 53**
 PRF, **36, 37, 54, 62**
 purge, **39, 40**

Q

Q-Switch, **5, 18, 35, 38, 45, 53, 54, 55, 56, 58**

R

RoHS, **iv**

S

sales support, **ii**

SHG, **16, 62**
shock hazard, **vi**
symbols, **v**

T

technical support, **ii**

test report, **4, 5, 15, 32, 33, 34, 35, 46**

W

Warning Labels, **9**

WEEE, **iv**